

CHAPTER 21.07: DEVELOPMENT AND DESIGN STANDARDS

21.07.010	GENERAL PROVISIONS	3
A.	Purpose	3
B.	Buildings to Have Access	3
C.	Addresses	3
D.	Alternative Equivalent Compliance	3
E.	Urban Neighborhood Development Context Standards	5
21.07.020	NATURAL RESOURCE PROTECTION	6
A.	Purpose	6
B.	Stream, Water Body, and Wetland Protection	7
C.	Steep Slope Development	15
D.	Wildlife Management Corridors	21
E.	Flood Hazard Area Regulations	22
21.07.030	PRIVATE OPEN SPACE	31
A.	Purpose	31
B.	Applicability and Open Space Requirement	32
C.	Exemptions	32
D.	Standards	33
21.07.040	DRAINAGE, STORM WATER TREATMENT, EROSION CONTROL, AND PROHIBITED DISCHARGES	35
A.	Purpose	35
B.	Guidance Documents	36
C.	Emergencies	36
D.	Drainage	36
E.	Storm Water Treatment and Erosion and Sediment Control	37
F.	Snow Storage and Disposal	40
G.	Prohibited Discharges	42
H.	Hazardous Sites	43
I.	Violations and Penalties	44
J.	Appeals	44
21.07.050	UTILITY DISTRIBUTION FACILITIES	44
A.	Underground Placement Required for New or Relocated Lines	44
B.	Exceptions	45
C.	Variances	45
D.	Relationship to Chapter 21.13, <i>Nonconformities</i>	46
E.	Nonconforming Overhead Lines in Dedicated Municipal Parks	46
F.	Designation of Target Areas	46
G.	Nonconforming Overhead Lines	48
H.	Lines in Municipal Right-of-Way	49
I.	Conversion of Service Connections	49
J.	Landscaping	49
21.07.060	TRANSPORTATION AND CONNECTIVITY	50
A.	Purpose	50
B.	Applicability	50
C.	Traffic Impact Mitigation	50
D.	Streets and On-Site Vehicular Circulation	51
E.	Standards for Pedestrian Facilities	53
F.	Pedestrian Frontage Standard	56
G.	Pedestrian Amenities Menu	59
21.07.070	NEIGHBORHOOD PROTECTION STANDARDS	67
A.	Purpose and Relationship to Other Requirements	67
B.	Discretionary Conditions	67

C.	Nonresidential Development Adjacent to Existing Residential Use	67
D.	Residential Development Adjacent To Existing Nonresidential Use	68
21.07.080	LANDSCAPING, SCREENING, AND FENCES	68
A.	Purpose	68
B.	Exemption for Temporary Uses	69
C.	Landscape Plan	69
D.	Cross-References to Other Requirements	69
E.	Types of Landscaping	70
F.	General Landscaping Requirements and Standards	78
G.	Screening.....	81
H.	Fences	84
21.07.090	OFF-STREET PARKING AND LOADING	86
A.	Purpose	86
B.	Applicability	86
C.	Computation of Parking and Loading Requirements	87
D.	Parking Lot Layout and Design Plan	88
E.	Off-Street Parking Requirements	89
F.	Parking Usage Reductions; Alternative Transportation Incentives	90
G.	Off-Street Loading Requirements.....	91
H.	Parking and Loading Facility Design Standards.....	94
I.	Passenger Loading Zones.....	105
J.	Accessible Parking Spaces	106
K.	Bicycle Parking Spaces	109
L.	Vehicle Queuing Spaces	112
M.	Structured Parking.....	114
21.07.100	EXTERIOR LIGHTING	116
21.07.110	RESIDENTIAL DESIGN STANDARDS	116
A.	Purpose	116
B.	Alternatives and Flexibility	116
C.	Standards for Multifamily and Townhouse Residential	117
D.	Standards for Some Single-Family and Two-Family Residential Structures	124
E.	Site Design	125
F.	Affordable Housing	127
G.	Conditional Use for a Residential Planned Unit Development.....	127
21.07.115	NONRESIDENTIAL DEVELOPMENT	130
A.	Conditional Use for a Business-Industrial Park Planned Unit Development.....	130
B.	Conditional Use for a Planned Unit Development in the DT Districts.	132
21.07.120.	LARGE ESTABLISHMENTS	133
A.	Large Commercial Establishments.....	133
B.	Large Non-Residential Establishments in or Surrounded by Large Lot Residential Districts	139
C.	Tall Buildings	140
21.07.130	SKYWALKS AND OTHER PROJECTIONS INTO PUBLIC AIRSPACE.....	140
21.07.140	OPERATIONAL STANDARDS.....	141
A.	Purpose	141
B.	Applicability.....	141
C.	Standard	141

CHAPTER 21.07: DEVELOPMENT AND DESIGN STANDARDS

21.07.010 GENERAL PROVISIONS

A. Purpose

The development and design standards set forth in this chapter shall apply to the physical layout and design of development in the municipality. These provisions address the physical relationship between development and adjacent properties, public streets, neighborhoods, and the natural environment, in order to implement the comprehensive plan vision for a more attractive, efficient, and livable community. The specific purposes of this chapter include:

1. To encourage the proper use of the land by promoting an appropriate balance between the built environment and the preservation and protection of open space and natural resources;
2. To provide standards that reasonably balance community goals, economic growth, quality of life, and development costs;
3. Promote the protection of natural features and resources, water quality and hydrological functions, and important or hazardous environmental areas;
4. To provide appropriate standards to ensure a high quality appearance for the municipality and promote good design while also allowing flexibility, individuality, creativity, and artistic expression;
5. To provide development and design standards that address and are tailored to the municipality's northern climate and winter city character;
6. To protect and enhance residential neighborhoods, commercial districts, and other areas by encouraging physical development that is of high quality and is compatible with the character, scale, and function of the surrounding area;
7. To encourage developments that relate to adjoining public streets, open spaces, and neighborhoods with building orientation and physical connections that contribute to the surrounding network of streets, walkways, pathways, and trails.

B. Buildings to Have Access

Every building shall be on a lot abutting on a constructed public street with principal access to such street, or with access to a constructed private street approved by the appropriate fire authority, public works department, and community development department. This standard may be waived by approval of the municipal engineer, traffic engineer, and the director.

C. Addresses

It is the responsibility of the property owner to affix street address numbers assigned by the municipality to the affected building(s) or on another structure (natural or otherwise) nearer to the street, to be plainly visible and legible from the street named in the address. Sub-addresses shall also be visible when approaching the building and on each applicable entrance.

D. Alternative Equivalent Compliance

1. Purpose

Alternative equivalent compliance is a procedure that allows development to meet the intent of this title through an alternative design. The procedure permits a site-specific plan that is equal to or better than the strict application of a design standard specified in this title. This procedure is not intended as a substitute for a variance or administrative modification or as a vehicle for relief from standards in this title.

2. Applicability

The alternative equivalent compliance procedure shall be available only for the following sections of this title:

- a. Subsection 21.06.030D.7.c., *Height/Bulk Transitions*;
- b. Subsection 21.06.030D.8., *Height Transitions for Neighborhood Compatibility*;
- c. Subsection 21.07.060F., *Pedestrian Frontage Standard*;
- d. Subsection 21.07.060G., *Pedestrian Amenities*;
- e. Subsection 21.07.080, *Landscaping, Screening, and Fences*;
- f. Subsection 21.07.090M.3., *Structured Parking; Façade Treatment*;
- g. Section 21.07.110, *Residential Design Standards*;
- h. Section 21.07.120, *Large Commercial Establishments*;
- i. Subsection 21.09.080, *Building Design Standards (Girdwood)*; and
- j. Chapter 21.11, *Downtown*.

3. Pre-Application Conference Required

An applicant proposing to use alternative equivalent compliance under this section shall request and attend a pre-application conference prior to submitting the site plan for the development, to determine the preliminary response from the director. Based on that response, the site plan application shall include sufficient explanation and justification, in both written and graphic form, for the alternative compliance requested.

4. Decision-Making Responsibility

Final approval of alternative equivalent compliance under this section shall be the responsibility of the decision-making body responsible for deciding upon the application. By-right projects that are reviewed for compliance with this title through the land use permit process, yet which are proposing alternative equivalent compliance, shall receive written approval of the alternative equivalent compliance from the director.

5. Timing of Decision

If the director is the decision-making body, the director shall render a written decision within 21 days of receipt of an application for alternative compliance. Should a decision not be rendered within 30 days, the application shall stand as approved.

6. Criteria

To grant a request for alternative equivalent compliance, the decision-making body shall find that all of the following criteria are met:

- a. The proposed alternative design achieves the intent of the subject design standard to the same or better degree than the subject standard.
- b. The proposed alternative design achieves the goals and policies of the comprehensive plan to the same or better degree than the subject standard.
- c. The proposed alternative design results in benefits to the community that are equivalent to or better than compliance with the subject design standard.

7. Effect of Approval

Alternative compliance shall apply only to the specific site for which it is requested and does not establish a precedent for assured approval of other requests.

E. Urban Neighborhood Development Context Standards

1. Purpose

This section establishes an Urban Neighborhood Development Context Standards area that reflects the existing and desired characteristics of Anchorage's older, urban neighborhoods identified by the Comprehensive Plan, Land Use Plan Map as Traditional Neighborhood Design areas. This section provides a basis for development regulations tailored to the characteristics of these neighborhoods and fulfills their role as recommended in the Comprehensive Plan.

- a. This area is intended to include Anchorage's original urban neighborhoods of Government Hill, South Addition, and Fairview, and post-ware era (1950s-1960s) neighborhoods such as Spenard, Airport Heights, and Russian Jack Park. It also includes transit-supportive development corridors and designated mixed-use centers.
- b. This area recognizes urban neighborhood characteristics including a more highly interconnected street system, smaller lot and block sizes, and access to pedestrian facilities and public transit. Some neighborhoods have consistent or frequent sidewalks and alleys. Buildings and residences often have moderate front setbacks and orient to the street, with landscaping or walkways (instead of parking) comprising most of their street frontage. Transit-supportive development corridors and mixed-use centers contribute to a compact, accessible land use pattern.

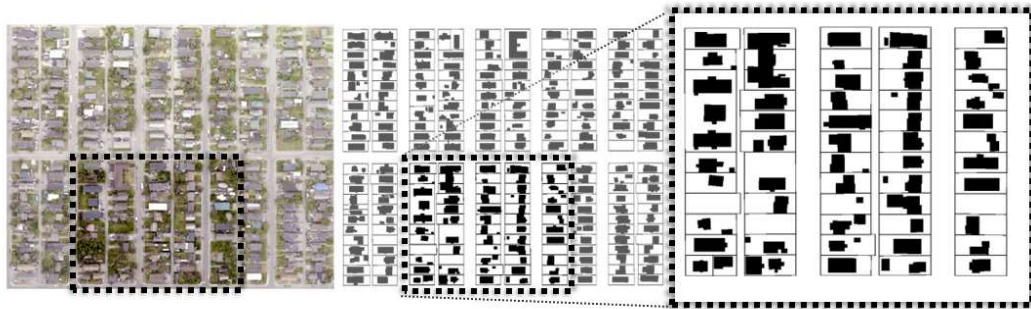

Regular street grid of city blocks and alleys in Mountain View.



More relaxed street grid along a transit corridor in Spenard.

2. Applicability

The urban neighborhood development context standards shall apply as a basis for area-specific development standards in this chapter 21.07. It shall not be used as a basis to change allowed uses or review and approval procedures of the underlying zoning district, district-specific dimensional standards, or any other standards elsewhere in this title. Urban neighborhood development context standards shall be effective November 1, 2025.

3. Urban Neighborhood Development Context Standards Established.

The urban neighborhood development context area is delineated in map 21.07-1, with the following clarifications:

- a. Birchwood Park, DeBarr Vista, and Green Acres Subdivisions (and Additions) are included (marked “A” on map).
- b. The Downtown (DT) zoning districts are not included. The university and medical campuses of the UMED District are also not included.
- c. The properties of Merrill Field Airport, Alaska Railroad Terminal Reserve, and Port of Alaska are not included.
- d. Broadmore Estates, Bentzen Addition, Creekside Park, Town Square, Tudor Park, University Park, and Windemere Subdivisions (and their Additions) are not included (marked “B” on map).



(AO 2012-124(S), 2-26-13; AO 2013-117, 12-3-13; AO 2020-11, 2-25-20; AO 2020-38, 4-28-20; AO 2022-36, 4-26-22; AO 2023-43, 4-25-23; AO 2023-50, 7-11-23; AO 2024-23, 2-27-24; AO2024-24, 4-23-24)

21.07.020 NATURAL RESOURCE PROTECTION

A. Purpose

The municipality contains many natural amenities including streams, natural drainages, wildlife habitat areas, water bodies, scenic features such as mountains and coastal areas, wetlands, and hillsides, as well as significant amounts of native forest, tree cover, and open space, all of which contribute to the municipality’s character, public health, quality of life, and property values. The

requirements of this section are intended to ensure that the natural character of the municipality is reflected in patterns of development and redevelopment, where feasible and appropriate.

B. Stream, Water Body, and Wetland Protection

1. Purpose

The following requirements are intended to promote, preserve, and enhance the important hydrologic, ecological, and aesthetic functions provided by watercourses, water bodies, and wetlands. Natural setbacks protect water quality and quantity and property values. By minimizing impervious surfaces and maintaining natural vegetation, setbacks also prevent costly erosion, flooding, pollution, and the spread of invasive plants.

These regulations recognize the interests of landowners of existing lots to make reasonable use of the land, while balancing interests of downstream landowners in protecting their property, by allowing uses that will conserve and protect streams, riparian vegetation, wetlands, and water bodies.

2. Applicability

This subsection applies in all zoning districts and to all development in the municipality, unless specifically exempted in this or another section of title 21.

3. Legally Established Uses

See section 21.13.045 for provisions relating to uses of setback areas that were legally established.

4. Relationship to Other Regulations

- a. This subsection 21.07.020B. does not repeal or supersede any existing federal, state, or local laws. When this subsection imposes a higher or more restrictive standard than found in another applicable ordinance, statute, or regulation, this subsection shall apply.
- b. No person shall engage in any activity that will disturb, remove, drain, fill, dredge, clear, destroy, or alter any area, including vegetation, within a wetland that falls in the jurisdiction of the federal government and its agencies, except as may be expressly allowed under a permit issued by the appropriate federal agency.
- c. The decision-making body may grant final approval to any development or activity, including subdivisions and rezonings, in a wetland that falls within the federal government's jurisdiction conditioned upon all necessary federal approvals and permits having been obtained.
- d. Stream, drainageway, water body, and wetland setback areas shall be credited toward any applicable private open space requirements or landscaping requirements only if such setback areas serve the purposes of those requirements as set forth in this title.

5. Drainageways

For all drainageways, flow paths may not be obstructed without providing an alternate drainage path in accordance with B.7. below.

6. Stream Channel Alteration

A stream shall not be moved, ditched, or piped, except as follows:

- a. The applicable federal and state agencies have authorized the alteration, and

- b. Watershed Management Services has authorized the alteration, after considering potential impacts including the following items:
 - i. Practical alternatives to moving, piping, or otherwise altering the channel.
 - ii. The potential to increase flooding or erosion problems upstream or downstream.
 - iii. Any potential obstruction of water flow.
 - iv. The flow lines of the altered section of the channel as related to those in the existing channel at the endpoints of the alteration.
 - v. The adequacy of the gradient/meander balance, grade control, and bed stability to maintain the natural stream function of water conveyance and sediment transport.
 - vi. If applicable, the impact on fish habitat or fish passage.
 - vii. The alteration does not increase the setback on adjacent properties without written permission from the impacted property owner(s). This written permission shall be recorded in the Anchorage Recording District, Third Judicial District, State of Alaska.
 - viii. The alteration will not lead to an increase in flooding, erosion, or icing problems upstream or downstream.

7. Drainageway Alteration

A drainageway may be moved, culverted, or piped, in a manner that preserves drainage continuity, subject to the following:

- a. Authorization from a state or federal agency, if under the jurisdiction of such agency;
- b. Authorization from Watershed Management Services; and
- c. The alteration will not lead to an increase in flooding, erosion, or icing problems upstream or downstream.

8. Boundary Delineation

a. Official Definitions and Standards

- i. In cases where watercourses or water bodies are not mapped and recorded in official plans or other documents, delineation of such features shall be made according to Watershed Management Services procedures, and shall be subject to formal verification by Watershed Management Services.
- ii. In cases where wetlands are not mapped and recorded in official plans or other documents, including the *Anchorage Wetlands Management Plan*, delineation of such features shall be performed using procedures as described by the U.S. Army Corps of Engineers. Delineations shall be subject to formal verification by the U.S. Army Corps of Engineers, which may expire.

b. Water Course Boundaries

- i. Water course boundaries shall be delineated at the ordinary high-water mark or, if not readily discernible, the defined bank of the stream, as those terms are defined in chapter 21.15. In those instances where the defined bank of the water course is not readily discernible, Watershed

Management Services shall establish the effective ordinary high-water mark. Watershed Management Services shall maintain the official record of the centerline of all watercourses.

- ii. All new plats of record after October 9, 2018, shall show the centerline of all streams and major drainageways. A plat note shall be included indicating that setbacks are according to the current physical location of the stream or drainageway and current version of title 21.

c. Wetland Boundaries

i. Mapped Wetlands

Boundary delineation of wetlands shall be established by reference to the *Anchorage Wetlands Management Plan*, an element of the Anchorage comprehensive plan. Preliminary plats shall depict, or otherwise annotate, wetland boundaries.

ii. Unmapped Wetlands

The review of a development proposal may discover a potential wetland that has not been mapped or for which the boundaries have not been clearly established. In such instances, the boundaries of the wetland shall be delineated according to subsection 5.a.ii. above. Any new wetland boundaries delineated herein shall be submitted to the U.S. corps of engineers for approval.

9. Stream Setbacks

Stream setbacks are intended to reflect the size and characteristics of the waterbody, as well as the pattern of adjacent land development. Large, meandering streams require larger buffers than small, channelized streams. Similarly, large buffers provide greater benefit where intact riparian areas exist than those along sections of streams with encroaching development.

a. Designation

Stream setbacks are established around all streams in the municipality. Stream setbacks comprise two distinct zones: the streamside zone and the riparian edge zone.

b. Setback Widths for Streams

i. Stream setback widths shall be measured horizontally starting from the ordinary high-water mark or, if the ordinary high water mark is not readily discernible, from each side of the defined bank of the stream.

ii. Required minimum stream setback widths shall be as provided in table 21.07-1 below. Exceptions to setback widths are provided in subsection 9.c. below.

iii. For parcels where there are wetlands contiguous with a stream, additional setback requirements are listed in the Wetland Designation and Enforceable and Administrative Policies and Management Strategies tables of the Anchorage Wetlands Management Plan.

TABLE 21.07-1. MINIMUM STREAM SETBACK WIDTH PER SIDE

Stream	Streamside Zone	Riparian Edge Zone	Total Stream Setback Width Per Side
Bird Creek, California Creek, Eagle River, Eklutna River, Glacier Creek, Knik River, Placer River Portage Creek, Skookum Creek, Twentymile River,	25 feet	75 feet	100 feet
Bayshore Creek, Campbell Creek, Carol Creek, Chester Creek, Clunie Creek, Craig Creek, Crow Creek, Crystal Creek, Edmonds Lake Creek, Elmore Creek, Falling Water Creek, Fire Creek, Fossil Creek, Gunnery Creek, Hidden Creek, Indian Creek, Kern Creek, Little Peters Creek, Little Campbell Creek, Little Rabbit Creek, Little Survival Creek, Meadow Creek, McHugh Creek, Mink Creek, Mirror Creek, Parks Creek, North Branch North Fork Little Campbell Creek, North Fork Campbell Creek, North Fork Little Campbell Creek, Penguin Creek, Peters Creek, Peterson Creek, Potter Creek, Rabbit Creek, Ship Creek, South Fork Campbell Creek, South Fork Eagle River, South Branch North Fork Little Campbell Creek, South Fork Little Campbell Creek, Stuckagain Creek, Rainbow Creek, Tidewater Slough, Thunderbird Creek, Tiny Creek, Virgin Creek, Winner Creek,	25 feet	25 feet	50 Feet
Alyeska Creek, Eagle Loop Creek, Fish Creek, Furrow Creek, Hood Creek, Middle Fork Chester Creek, Moose Meadows Creek, North Fork Chester Creek, North Branch South Fork Chester Creek, Reflection Lake Creek, All other streams and unnamed stream tributaries	25 feet	0 feet	25 feet
Within the Hillside Watershed Protection Area: All named streams listed above	50 feet	0 feet	50 feet
Within the Hillside Watershed Protection Area: All other streams and unnamed stream tributaries	25 feet	25 feet	50 feet
Ephemeral channels	10 feet	0 feet	10 feet

c. Exceptions

- i. **Stream Setback Limited to 25-Foot on Small, Existing Parcels**
Platted parcels, existing as of October 9, 2018, abutting or encompassing a stream and less than 10,000 square feet in size are subject to only the 25-foot wide streamside zone stream setback requirement.
- ii. **Hillside Watershed Protection Area**
Platted parcels, existing as of October 9, 2018, abutting or encompassing a stream and less than 50,000 square feet in size, the 25-foot wide streamside zone stream setback and 25-foot riparian edge zone setbacks shall apply within the footprint of existing disturbances that are nonconforming with this subsection. In naturally vegetated areas not disturbed as of this date, only the uses/activities permitted in a streamside zone shall be permitted within the total 50-foot setback area.
- iii. **Streams in Pipes or Culverts**
Segments of streams contained in pipes or culverts longer than 50 feet are exempt from the stream setback requirement. In cases where a drainage easement does not exist along the piped section of stream, a piped conveyance of any length will have a setback in accordance with B.10 below.
- iv. **Streets in Stream Setbacks**
Where a street or railroad existing as of October 9, 2018 is located within a stream setback, the setback on the street side shall extend only to the edge of the improved street or railroad and not continue over or past the improvement. The full setback shall exist on the non-street side of the stream.
- v. **Alternate Means of Compliance and Alternate Setback Options; Including Urban Stream Restoration and Stream Daylighting Projects, Stream-Related Greenway Development Projects, and Similar Actions for the Comprehensive Plan.**
 - (A) The provisions of this section are not intended to prevent the implementation of measures or activities that achieve the goals outlined in B.1. above, or elements of the Comprehensive Plan, unless specifically prohibited by this code, and provided the alternate means of compliance are approved by Watershed Management Services.
 - (B) Watershed Management Services may approve any such alternate means of compliance provided that they find that the proposed design complies with the intent and purpose of this code, protects the integrity of stream buffers, and are resistant to effects of flooding, erosion and icing, in accordance with subsection B.6. above.
 - (C) The details of any action granting modifications or the acceptance of a compliance alternative shall be recorded and entered into Watershed Management Services files.

d. Streamside Zone

The uses/activities (and their maintenance) listed below are permitted in the streamside zone. Otherwise, no disturbance of the streamside zone is permitted. After disturbance associated with the uses/activities below, all disturbed areas shall be revegetated with non-invasive trees, shrubs, and ground cover similar to natural vegetation in the area. Revegetation shall occur during the same growing

season as the disturbance activity, except as otherwise permitted by Watershed Management Services.

- i. Vegetation maintenance or removal, in accordance with subsection B.13. below.
- ii. Stream channel and/or stream bank enhancement and/or restoration activities, when authorized by Watershed Management Services.
- iii. Utility mainline and service lines, road, and/or trail crossings, as close to perpendicular to the stream channel as possible. This exception does not apply to utility components that are chiefly part of a building, such as pedestals, masts, meters, etc.
- iv. Flood prevention/control measures and storm water infrastructure, when authorized by Watershed Management Services
- v. Hydro power generation infrastructure, by administrative site plan review to minimize impacts to the setback area.
- vi. Soft surface trails and elevated walkways. Trails and walkways running parallel to streams should generally be located at least 10 feet from streams. Through the design and permitting process, trails may be located closer to the stream for a justified reason, such as overcoming a physical, topographical, or land ownership constraint, or taking advantage of a viewpoint..
- vii. Structures used for fishing platforms, stream overlooks, wildlife viewing.
- viii. Stream gaging and water quality monitoring.
- ix. Emergency action(s) necessary to prevent imminent threat or danger to public health or safety, or to public or private property, or serious environmental degradation may be taken at any time without advance notice; provided that, the notice shall be given at the earliest opportunity thereafter. These actions may be subject to the conditions of other municipal, state, or federal regulations.

e. Riparian Edge Zone

The uses/activities (and their maintenance) listed below are permitted in the riparian edge zone. Otherwise, no disturbance of the riparian edge zone is permitted. After disturbance associated with the uses/activities below, all disturbed areas shall be revegetated with non-invasive trees, shrubs, and ground cover similar to natural vegetation in the area. Revegetation shall occur during the same growing season as the disturbance activity, except as otherwise permitted by Watershed Management Services.

- i. Utilities service and main lines running parallel to the stream channel, when determined by the utility and Watershed Management Services that no other alternative exists. Access to such utilities for maintenance shall be at specific points rather than parallel to the utility corridor whenever possible. This exception does not apply to utility components that are chiefly part of a building, such as pedestals, masts, meters, etc.
- ii. Paved or unpaved trails. Trails must be constructed near natural grade to minimize clearing, filling, and grading.
- iii. Recreational fields and golf course fairways open to the public.

- iv. Gardens, lawn, and other residential landscaping, up to one-half of the riparian edge zone area on the lot.
- v. Accessory structures less than 150 square feet and not on a permanent foundation.
- vi. Decks, not to exceed 500 square feet.
- vii. Wells.
- viii. Snow storage, in accordance with subsection 21.07.040F.8.
- ix. The development footprint of items iv, v, vi, vii, and viii of the subsection may not cumulatively exceed one-half of the riparian edge zone on the lot.

10. Major Drainageway Setbacks

a. Purpose

Drainageways provide for the orderly drainage of stormwater, snowmelt, groundwater discharge, and all other perennial or intermittent flows. Drainageway setbacks are necessary for the preservation of drainage continuity under current and future development.

b. Setback Widths

Buildings and accessory structures shall be set back no less than 10 feet horizontally from the edge of each side of a major drainageway, or from the middle of the major drainageway if no defined channel edge exists. Major drainageways are defined or verified by Watershed Management Services. Watershed Management Services may require a greater setback for major drainageways if, in their professional judgment, the additional setback is necessary to prevent damage to property, reduce risk to health or safety or necessary to comply with other municipal, state, or federal requirements.

c. Uses in the Setback

The drainageway setback shall be maintained in a stable and non-eroding state. Nothing in the drainageway setback shall inhibit the passage of drainage flows, or cause erosion and/or icing.

11. Water Body Setbacks

a. Setback Widths

All water bodies shall have setbacks. Buildings, accessory structures, and other impervious surfaces shall be set back at least 25 feet horizontally from the ordinary high water mark of water bodies, except as allowed below. When wetlands are present and contiguous to the water body, additional setback requirements are listed in the Anchorage Wetlands Management Plan.

b. Allowed and Prohibited Uses

The uses/activities (and their maintenance) listed below are permitted in the water body setback. Otherwise, the setback shall be vegetated.

- i. Water-related accessory structures less than 500 square feet, such as boathouses or floatplane storage buildings. If the water body setback coincides with the side or rear setback of the lot, this allowance shall supersede the size limitation of subsection 21.05.070B.3.b.ii.
- ii. Minimal areas to allow for access to uses, such as docks, boathouses, and floatplane storage, that require direct access to a water body by their very nature or function.

- iii. Municipal beaches and associated structures/facilities.
- iv. Structures used for fishing platforms, water body overlooks, wildlife viewing, and the like, when authorized by Watershed Management Services.

12. Wetland Setbacks

a. Setback Widths

All wetlands shall have setbacks. All buildings, accessory structures, fills, storage of materials, and impervious surfaces shall be set back at least 15 feet horizontally from the delineated edge of all wetlands except those authorized for development.

b. Allowed and Prohibited Uses

No disturbance is permitted in the 15-foot setback area, other than access to permitted decks, boardwalks, and wildlife viewing platforms.

c. Implementation of the Anchorage Wetlands Management Plan

i. Zoning and Platting Actions

Zoning and platting actions taken under this title shall be consistent with the Anchorage Wetlands Management Plan. When feasible, accounting for lot sizes and configurations, access needs, and viable economic use of land, class A and those class B wetlands which, as a result of a U.S. Army Corps of Engineers decision or permit condition, are not authorized for development, shall be platted into separate tracts and not included as part of a development lot. Wetland classes are defined and delineated in the Anchorage Wetlands Management Plan.

ii. Application of Plan to Approved Projects

Conditional uses and preliminary plats approved prior to July 9, 2014, the date of adoption of the current Anchorage Wetlands Management Plan, shall not have additional conditions imposed upon them as a result of requirements of the plan except as follows:

- (A) The "A" wetland designation shall apply regardless of prior approvals.
- (B) Approved plats or conditional uses in wetlands that are returned to the platting authority or planning and zoning commission for major amendment may be examined for conformity with goals and enforceable policies of the Anchorage Wetlands Management Plan.
- (C) A new U.S. Army Corps of Engineers permit is required.

13. Maintenance

Maintenance, modification, or removal of trees or shrubs from stream, water body, or wetland setback areas is allowed as follows:

- a. Pruning of trees and woody shrubs for the health and/or renewal of vegetation shall not result in removal of more than 25% of the living crown of a tree, nor jeopardize the health and natural shape of a tree or shrub.
- b. With Alaska Department of Fish and Game authorization, the removal of downed trees from the stream channel is allowed. The root structure shall be left for ground stabilization.

- c. A tree or shrub, or portion thereof, may be removed for one or more of the following reasons. If necessary, clarification of these conditions shall be obtained from Watershed Management Services:
 - i. The tree or shrub, or portion thereof, is dead.
 - ii. The tree or shrub is a safety hazard to person, property, or public.
 - iii. The tree or shrub removal is for the purpose of preventing the spread of disease to other trees.
 - iv. As part of a coordinated invasive plant control project approved by a relevant municipal, state, or federal agency.
- d. Whenever a damaged, dead, or diseased tree is removed, it shall be replaced with another tree having a minimum diameter of two inches at 4.5 feet above ground. Whenever a shrub is removed, it shall be replaced with another shrub having a minimum height at time of planting of 18 inches.
- e. The use of herbicides for the control or removal of vegetation is prohibited in the streamside zone unless otherwise approved by Watershed Management Services.
- f. Unless otherwise accepted by the municipality, any maintenance of the stream setback shall be the responsibility of the property owner.

14. Violations

Where a violation of this subsection has been established, restoration approved by Watershed Management Services shall be required. All disturbed areas shall be revegetated with non-invasive trees, shrubs, and ground cover similar to natural vegetation in the area. Revegetation shall occur during the same growing season as the disturbance activity, except as otherwise permitted by Watershed Management Services.

C. Steep Slope Development

1. Purpose

The purpose of this subsection 21.07.020C. is to establish standards that help achieve the following objectives for development on steep slopes:

- a. Prevent soil erosion and landslides;
- b. Provide safe circulation of vehicular and pedestrian traffic to and within hillside areas and to provide access for emergency vehicles necessary to serve the hillside areas;
- c. Encourage only minimal grading that relates to the natural contour of the land and discourage mass grading of large pads and excessive terracing;
- d. Encourage building types, grading design, lot sizes, site design, density, arrangement, and spacing of buildings in developments in sloped areas that integrate into the natural terrain with minimal re-contouring, in accordance with adopted goals and policies;
- e. Encourage innovative architectural, landscaping, circulation, and site design;
- f. Encourage the protection of visually significant and/or prominent natural features, such as ridgelines and rock outcroppings;
- g. Incorporate drainage design that does not adversely impact neighboring or nearby properties, downstream properties, receiving waters, and public infrastructure; and

- h. Encourage the retention of natural, indigenous vegetation that provides wildlife habitat, helps retain runoff, and maintains the area's visual character.

2. Applicability

- a. Except as noted in subsection 2.b. and 2.c below, any lot with an average slope of 20 percent or greater, or where adverse conditions associated with slope stability, erosion, or sedimentation are present as determined by the municipal engineer, shall comply with the standards of this subsection 21.07.020C. Lots being subdivided shall comply with chapter 21.08, including subsection 21.08.030H., Subdivisions on Slopes, if applicable.
- b. This section applies to naturally occurring steep slopes and not to those that result from human activities, such as gravel extraction.
- c. Buildings within Class A zoning districts (subsection 21.08.050B.) are exempt from these requirements.

3. Standards

Except as allowed in subsection C.4. below, all proposed development subject to this section shall comply with the following standards.

a. Determination of Original/Natural Grade

Original/natural grade shall be as defined in chapter 21.15. If there has been previous development on the lot (e.g., gravel extraction), the director shall determine original/natural grade, taking into account the previous development, the existing grade of surrounding lots, the availability of information on pre-development grade, and the feasibility of using pre-development grade.

b. Slopes Greater than 30 Percent

That contiguous portion of any lot which is 5,000 square feet or larger with slopes steeper than 30 percent shall remain undisturbed, except as allowed in subsection C.4. below.

c. Site Disturbance Envelope

i. There shall be a site disturbance envelope on each applicable lot. Earth disturbance and vegetation clearing shall be limited to the site disturbance envelope. Clearing, grubbing, or grading outside the site disturbance envelope is prohibited except to modify fuels in order to reduce fire risk, or to accommodate utility service connections.

ii. The size of the site disturbance envelope shall be as follows:

(A) Lots less than 40,000 square feet: 10,000 square feet maximum or 50 percent of the lot area maximum, whichever is less.

(B) Lots 40,000 square feet to two acres in area: 20,000 square feet maximum.

(C) Lots over two acres but less than five acres: 30,000 square feet maximum.

(D) Lots five acres or greater: 40,000 square feet maximum.

iii. Areas outside the site disturbance envelope shall not be used for stockpiling materials or excess fill, construction vehicle access, storage of vehicles during construction, or similar uses. Temporary construction fencing or flagging shall be installed around the perimeter of the site

- disturbance envelope, to be removed after the final certificate of zoning compliance is issued.
- iv. The front setback of the lot may be reduced to 10 feet.
 - v. If the average slope of the site disturbance envelope is less than 20 percent, the development is exempt from subsections 3.e., 3.f., 3.g., 3.h., and 3.i.
- d. **Cutting, Grading, and Filling**
- i. Cutting and grading to create benches or pads for buildings or structures shall be limited to within the site disturbance envelope.
 - ii. Cut and fill slopes shall be entirely contained within the site disturbance envelope. The toe of any fill slope not utilizing an engineered retaining structure, and any engineered retaining structure shall be a minimum of 15 feet from any property line, except for the property line abutting the street from which driveway access is taken.
 - iii. Cut and fill slopes shall be designed to provide a natural transition into the existing terrain by feathering and rounding.
- e. **Raising or Lowering of Natural Grade**
- The original, natural grade of a lot shall not be raised or lowered more than four feet at any point for construction of any structure or improvement, except:
- i. The site's original grade may be raised or lowered a maximum of six feet if retaining walls are used to reduce the steepness of constructed slopes, provided that the retaining walls comply with the requirements set forth in this subsection.
 - ii. As necessary to construct a driveway from the street to a garage or parking lot, grade changes or retaining walls up to six feet may be allowed.
 - iii. For the purposes of this subsection 21.07.020C.3.e., basements and buildings set into a slope are not considered to lower the natural grade within their footprint.
- f. **Retaining Walls**
- Retaining walls may be used to maximize the usable area on a lot within the site disturbance envelope. Generally, a retaining wall shall be no higher than six feet, except that a wall varied in height to accommodate a variable slope shall have an average height no greater than six feet and a maximum height no greater than eight feet in any 100-foot length. Parallel retaining walls may be used to overcome steep slopes, provided the following standards are met:
- i. The minimum distance between walls shall be six feet;
 - ii. The maximum allowable slope between walls shall be 3H:1V; and
 - iii. The area between the walls shall be landscaped with one of the following per 20 linear feet, measured along the length of the lower retaining wall:
 - (A) One tree and six shrubs; or
 - (B) Three shrubs that are at least five feet high at the time of planting, and four other shrubs meeting the standards of section 21.07.080.

A higher wall is permitted:

- i. Where used internally at the split between one- and two-story portions of a building; and
 - ii. Where substantially hidden from public view at the rear of a building, where it may not exceed the eave height of the building.
 - g. **Natural Drainage Patterns**
 - i. Site design shall not change natural drainage patterns, except as provided below.
 - ii. All grading and drainage shall comply with section 21.07.040, title 23, the *Design Criteria Manual* (current approved edition), and the municipality's *Storm Water Treatment Plan Review Guidance Manual*.
 - iii. Except where otherwise provided in this section, development shall preserve the natural surface drainage pattern unique to each site as a result of topography and vegetation. Grading shall ensure that drainage flows away from all structures. Natural on-site drainage patterns may be modified on site only if the applicant shows that there will be no significant adverse environmental impacts on site or on adjacent properties. If natural drainage patterns are modified, appropriate stabilization techniques shall be employed.
 - iv. Development shall not adversely impact adjacent and surrounding drainage patterns.
 - h. **Ground Cover and Revegetation**

Ground cover and vegetation shall be maintained to control erosion and sedimentation. All areas that are denuded for any purpose shall be revegetated or the soils stabilized to prevent erosion and sedimentation prior to November 1 of the year of construction. No excavation shall be permitted after November 1 or before May 1 except under emergency conditions, as determined by the building official.
 - i. **Building Design Standards**

The purpose of the building design standards is to minimize site disturbance, avoid extreme grading required by large building pads on steep slopes, and reduce the risk of damage from natural hazards.

 - i. All buildings and structures shall have a foundation which has been designed by a professional engineer, architect, or other qualified professional.
 - ii. In all Class B zoning districts, where option b. (subsection 21.06.030D.4.b.) is used to establish the grade plane, structures are limited to three stories on the downslope side (except those area governed by chapter 10, where the number or stories is not limited).
- 4. **Slopes Greater Than 30 Percent**
 - a. **Purpose**

The requirements of this section are intended to allow consideration of development on slopes up to 50 percent. In order to assure the safety and stability of such development and to reduce offsite impacts, additional submittals are required as described in this subsection. Nothing in this subsection guarantees approval to disturb slopes greater than 30 percent.
 - b. **Applicability**

If the site disturbance envelope as defined in C.3.c. above contains slopes over 30 percent, the standards of this section shall apply.

- c. **Slopes Greater Than 50 Percent**
All slopes greater than 50 percent shall remain undisturbed.
- d. **Existing Lots**
Notwithstanding other standards of this section, lots existing on January 1, 2014 that, due to the prevalence and/or distribution of slopes over 50 percent, are not able to meet these standards, are allowed a site disturbance envelope of 20,000 square feet. Within this site disturbance envelope, slopes over 50 percent are allowed to be disturbed.
- e. **Administrative Site Plan Review Required**
Development on slopes greater than 30 percent but not exceeding 50 percent requires an administrative site plan review. In addition to the site plan approval criteria set forth in subsection 21.03.180F., the approval criteria in subsection 4.g. below shall apply.
- f. **Additional Submittal Requirements**
In addition to the submittal requirements for an administrative site plan review, the following information is required:
 - i. A geotechnical engineering report, stamped by an engineer licensed in the state of Alaska, to include the following:
 - (A) Nature, distribution, strength, and stability of soils; conclusions and recommendations for grading procedures; recommendations for frequency of soil compaction testing, design criteria for corrective measures; and opinions and recommendations covering the adequacy of the site to be developed.
 - (B) Slope stability analysis: conclusions and recommendations concerning the effects on slope stability of excavation and fill, introduction of water (both on and offsite), seismic activity, and erosion.
 - (C) Foundation investigation: conclusions and recommendations concerning the effects of soil conditions on foundation and structural stability, including permeability, bearing capacity, and shear strength of soils.
 - (D) Specific recommendations for cut and fill slope stability, seepage and drainage control, or other design criteria to mitigate geologic hazards, slope failure, and soil erosion.
 - (E) Depth to groundwater in the wettest seasonal conditions, and to bedrock, if less than 15 feet.
 - (F) Complete description of the geology of the site, a complete description of bedrock and subsurface conditions and materials, including artificial fill, soil depth, avalanche and mass wasting hazard areas, fractures, or other significant features.
 - (G) A summary of field exploration methods and tests on which the report is based, such as probings, core drillings, borehole photography, or test pits. The public works department shall

confirm that the analysis methods and age of data are a reliable gauge of the site conditions and the potential impacts.

- ii. A site development plan showing the following:
 - (A) Site disturbance envelope as set forth in C.3.c. above.
 - (B) Location of all driveways, and utility lines and installations.
 - (C) Location of all structures.
 - (D) Elevation drawings of all structures.
- iii. Grading and drainage plans that provide the following:
 - (A) Topographic survey of existing conditions depicting at a minimum two foot contour intervals on a legible site map of one inch equaling 50 feet, or better.
 - (B) Proposed grading plan indicating limits of disturbed area, finished grade at minimum two foot contour intervals, proposed elevations of improvements, driveway grading at minimum 10 foot intervals measured on centerline, delineation of cut and fill areas, constructed slopes, proposed drainage features, and related construction.
 - (C) Drainage plans showing approximate locations for all surface and subsurface drainage devices, retaining walls, dams, sediment basins, storage reservoirs, and other protective devices to be constructed with, or as part of, the proposed work, together with a map showing drainage area, how roof and other impervious surface drainage will be disposed, the complete drainage network, including outfall lines and natural drainage ways which may be affected by the proposed development, and the estimated volume and rate of runoff of the area served by the drains.
 - (D) A plan for erosion control and other specific control practices to be employed on the disturbed area where necessary.
- iv. A revegetation plan that shows:
 - (A) The type, size, location, and grade of vegetation that will be used to complete the development plan and restore areas disturbed during construction, on a scaled plan of one inch equaling 30 feet, or better.
 - (B) Slope stabilization measures to be installed.

g. Standards

The following subsections apply to development under this subsection C.4.:

- i. 21.07.020C.3.c., *Site Disturbance Envelope*;
- ii. 21.07.020C.3.d., *Cutting, Grading, and Filling*;
- iii. 21.07.020C.3.g., *Natural Drainage Patterns*;
- iv. 21.07.020C.3.h., *Ground Cover and Revegetation*; and

v. 21.07.020C.3.i., *Building Design Standards*.

h. Approval Criteria

- i. The proposed development minimizes disruption of the natural topography and protects natural features on the site in their natural state to the greatest degree possible.
- ii. The principal and accessory structures have been sited in such a manner as to protect natural features of the site, minimize grading, preserve the appearance of scenic vistas, and minimize the risk of property damage and personal injury from natural hazards.
- iii. The design of the structures includes massing, roof lines, exterior materials and colors, and decking that complements the terrain and complies with the building design standards set forth in paragraph C.3.i. above.
- iv. Proposed landscaping preserves the natural character of the area while minimizing erosion and fire hazard risks to persons and property.
- v. The drainage design of the development will have no adverse impact on neighboring or nearby properties.
- vi. Areas not well suited for development due to soil stability characteristics, geology, hydrology limitations, or wastewater disposal, have been **avoided**.

D. Wildlife Management Corridors

1. Intent

The purpose of this section is to reduce wildlife-human conflicts by managing certain linear stream corridors to minimize adverse human-wildlife interactions and to facilitate more safely the movement of wildlife in those corridors identified in this section. It is not the intent of this section to reduce density that is otherwise allowed.

2. Applicability

This subsection shall apply within 200 feet on either side of the ordinary high water mark of the following streams: Peters Creek and its tributaries upstream of the Old Glenn Highway, Eagle River, South Fork of Eagle River (below the falls), Ship Creek (upstream from Reeve Blvd.), Campbell Creek (upstream from Lake Otis Parkway), North Fork of Little Campbell Creek (upstream from Elmore Road), Rabbit Creek, Little Rabbit Creek, Indian Creek, Bird Creek, Penguin Creek, California Creek, Glacier Creek, Virgin Creek and Portage Creek.

3. Standards

Within the area identified in subsection D.2. above, the following mandatory standards shall apply:

- a. No new landfills, solid waste transfer stations, schools, or campgrounds are allowed.
- b. All outdoor trash receptacles shall be bear-resistant, and food shall not be stored outside.
- c. Roads, driveways, or trails, including bridges, shall be designed to facilitate wildlife passage along streams and to minimize wildlife-human conflicts.
- d. Trails shall be sited with direct consultation with the state department of fish and game.

4. Discretionary Approvals

- a. For discretionary approvals before the planning and zoning commission, the urban design commission, the platting board, or the zoning board of examiners and appeals that include the area identified in subsection D.2. above, the following shall be considered during deliberations:
 - i. Location of new buildings, permanent structures, trails, and fences.
 - ii. Long-term retention of natural vegetation and terrain in a landscape pattern that provides cover for wildlife movement and directs wildlife away from residential structures or other structures occupied on a frequent basis.
- b. All applicable discretionary approvals under this section shall be referred to the Alaska department of fish and game, wildlife division, for their review, comments, and recommendations, which shall be considered by the decision-making body.

5. Review Report

All applications affected by this section shall be referred to the Alaska Department of Fish and Game for its review, comments, and recommendations, which shall be considered by the decision-making body. Recommendations for approval shall be supported by evidence in the report submitted by that department.

E. Flood Hazard Area Regulations

1. Purpose and Intent

The purpose of the flood hazard area regulations is to promote the public health, safety, and general welfare, and to minimize loss due to flood. The provisions of this section are intended to be an addition to all other land use regulations and to:

- a. Restrict or prohibit uses and structures that are dangerous to health, safety, or property in time of flood, or that cause increased flood heights or velocities;
- b. Require that uses vulnerable to floods, including public facilities that serve such uses, be provided with flood protection or flood proofing at the time of initial construction;
- c. Minimize the need for rescue and relief efforts associated with flooding and generally undertaken at the expense of the general public;
- d. Minimize prolonged business interruptions;
- e. Minimize damages to public facilities and utilities such as water and gas mains, electric, telephone and sewer lines, streets and bridges located in areas of flood hazard;
- f. Help maintain a stable tax base by providing for the sound use and development of areas of flood hazard so as to minimize future flood blight areas;
- g. Ensure that potential buyers are notified that property is in an area of flood hazard; and
- h. Ensure that those who occupy the areas of flood hazard assume responsibility for their actions.

2. Notice

Property owners affected by changes to the boundaries of the flood hazard area or by changes in the base flood elevations shall be noticed by mail.

3. Interpretation of Section; Disclaimer of Liability

- a. In the interpretation and application of this section, all provisions shall be:
- i. Considered as minimum requirements;
 - ii. Liberally construed in favor of the governing body; and
 - iii. Deemed neither to limit nor repeal any other powers granted under state statutes.
- b. The degree of flood protection required by this section is considered reasonable for regulatory purposes and is based on scientific and engineering considerations. Larger floods can and will occur on rare occasions. Flood heights may be increased by manmade or natural causes. This section does not imply that land outside the areas of flood hazard or uses permitted within such area will be free from flooding or flood damages. This section shall not create liability on the part of the municipality, any officer or employee thereof, or the Federal Insurance Administration for any flood damages that result from reliance on this section or any administrative decision lawfully made thereunder.

4. Creation of Flood Hazard Area; Official Flood Hazard Reports and Maps

a. *Creation of Area; Adoption of Reports and Maps*

There is hereby created a flood hazard area. This area shall be defined in its territorial extent by the following reports and maps:

- i. Flood insurance study for the municipality of Anchorage, prepared by the Federal Insurance Administration, Federal Emergency Management Agency (FEMA).
- ii. Flood insurance rate map (FIRM) prepared by the Federal Insurance Administration, FEMA, including the current digital flood insurance rate map (DFIRM) prepared by the Federal Insurance Administration.
- iii. Flood boundary and floodway map, prepared by the Federal Insurance Administration, FEMA, including the current digital flood boundary and floodway map prepared by the Federal Insurance Administration.
- iv. Flood hazard boundary map (FHBM), prepared by the Federal Insurance Administration, FEMA, including the current digital flood hazard boundary map (DFHBM) prepared by the Federal Insurance Administration.

The current editions of each of the maps and reports listed in this subsection are made a part of this section. Subsequent maps and reports prepared by the Federal Insurance Administration or the municipality delineating the flood hazard area, floodway and floodplain areas within the municipality shall become part of this chapter upon publication. A copy of the reports and maps cited in this subsection shall be on file in the department. Definitions of terms appearing on the maps and reports appear in 41 CFR 19.09.1.

b. *Flood Hazard Areas*

Within the flood hazard area, areas at a hazard for flooding include:

- i. Areas within the limit of the boundary of the base flood;
- ii. Areas within the highest extreme tide;
- iii. Areas covered in flood hazard studies prepared for the public works department that supplement the information prepared by FEMA; and

- iv. The stream setback area defined in subsection 21.07.020B.4.
 - c. **Review of Maps**

As necessitated by FEMA or the municipal engineer, the flood hazard district maps will be reviewed. The review may be conducted by the municipality, the U.S. corps of engineers, or the Federal Insurance Administration, and any new map panels or restudies affecting the boundaries of the flood hazard district, floodway, or floodway fringe area shall then be submitted to the planning and zoning commission for a recommendation and assembly for final adoption as part of this chapter.
 - d. **Rules for Interpretation of Flood Hazard Area Boundaries**

The boundaries of the flood hazard areas established by this chapter shall be determined from the cited maps and reports. Where interpretation is needed as to the exact location of the boundaries, the public works department, upon advice from the U.S. corps of engineers or FEMA, shall make the necessary interpretation.
5. **Regulations Applicable to Flood Hazard Area**
- a. **Applicability**

The regulations within this section shall apply to all areas of the flood hazard area.
 - b. **Prohibited Development**
 - i. Any encroachments, new construction, fill, obstructions, substantial improvements and other development or action within the regulatory floodway that would result in any increase in flood levels during the occurrence of a base flood are prohibited.
 - ii. Critical facilities shall not be located in the flood hazard area. For the purposes of this subsection only, critical facilities are defined as fire stations, police stations, hospitals, emergency shelters, schools, and emergency operations centers.
 - c. **Standards for Issuance of Building or Land Use Permit**

No building permits, encroachment permits, manufactured home permits, or other land use permits shall be issued for any development activity within the flood hazard area unless the plans show that, in addition to compliance with all other ordinances, regulations and permit requirements, the development shall meet the following requirements:

 - i. Prior to final approval of a permit it must be demonstrated that all necessary permits have been received from those governmental agencies from which approval is required by federal or state law, including section 404 of the Federal Water Pollution Control Act amendments of 1972.
 - ii. It must be demonstrated that structures will be reasonably safe from flooding. If a proposed building site is in a floodplain, all new construction and improvements shall be designed and adequately anchored to prevent flotation, collapse or lateral movement of the structure, be constructed with materials and utility equipment resistant to flood damage, and be constructed by methods and practices that minimize flood damage.
 - iii. The approval of a subdivision application or multi-unit development shall require proof that:
 - (A) The proposed construction is consistent with the need to minimize flood damage within the floodplain;

b. Floodway Fringe Area

The regulations listed in this subsection are applicable to the floodway fringe area:

- i. Permitted uses and structures are parks, parkways, greenbelts, land reserves, golf courses, playgrounds, playfields and related facilities.
- ii. Permitted accessory uses and structures are picnic tables, playground equipment, outdoor cooking facilities and like structures.
- iii. The following uses, structures and activities are permitted only by flood hazard permit: any use permitted by flood hazard permit as set forth in subsection a. of this section, and all other uses, structures and activities which are in accordance with all other land use regulations provided they are adequately floodproofed as set forth in subsection E.8. below, *Flood Hazard Permit*.
- iv. The following uses are prohibited: uses, structures and activities which are not permitted under subsections 6.b.i. through iii. of this section or which would cause violations of state water quality standards.

7. Construction Requirements

a. Generally

All new construction and substantial improvements in areas designated on the flood insurance rate map as zones A, A1-30, AE, and AH shall meet the following conditions:

- i. The lowest floor, including basement or crawl space, of residential structures shall be elevated to at least one foot above the base flood level. Within the structure, attendant utility and sanitary facilities shall be elevated to at least one foot above the base flood or completely floodproofed.
- ii. The lowest floor, including basement, of nonresidential structures shall be elevated to at least one foot above the base flood level, unless the structure, with all utility and sanitary facilities, is designed so that below base flood level the structure is watertight with walls substantially impermeable to the passage of water and so that it is capable of resisting hydrostatic and hydrodynamic loads and effects of buoyancy.
- iii. All fully enclosed areas below the lowest floor that are usable solely for parking, building access, or storage in an area other than a basement or crawlspace shall have a minimum of two openings having a total net area of not less than one square inch for every square foot of enclosed area according to FEMA specifications. The bottom of all openings shall be no higher than one foot above grade. Openings may be equipped with screens, louvers or other coverings or devices provided that they permit the automatic entry and exit of floodwaters.
- iv. Where floodproofing is utilized a registered professional engineer or architect shall certify that the floodproofing methods are adequate.
- v. For new manufactured home parks and manufactured home subdivisions; for expansions to existing manufactured home parks and manufactured home subdivisions; for existing manufactured home parks and manufactured home subdivisions where the repair, reconstruction or improvement of the streets, utilities and pads equals or exceeds 50 percent of value of the streets, utilities and pads before the repair, reconstruction or improvement has commenced; and for manufactured

homes not placed in a manufactured home park or manufactured home subdivision, require that the repair, and on all property not within a manufactured home park or subdivision stands or lots are elevated on compacted fill or on pilings so that:

- (A) The lowest floor of each manufactured home must be at least one foot above the base flood level.
 - (B) Adequate surface drainage and access for a hauler must be provided.
 - (C) For manufactured homes placed on pilings, pilings must be stable and no more than ten feet apart and reinforced if more than six feet above the ground level.
 - (D) Lots must be large enough to permit steps.
- vi. All manufactured homes to be placed or substantially improved shall be elevated on a permanent foundation such that the lowest floor of the manufactured home is at least one foot above the base flood elevation, and be securely anchored to an adequately anchored foundation system.
 - vii. All manufactured homes must likewise be anchored to prevent flotation, collapse or lateral movement, and shall be installed using methods and practices that minimize flood damage. Anchoring methods may include but are not limited to use of over-the-top or frame ties to ground anchors.

b. *Standards for Shallow Flood Areas (AO Zones)*

Shallow flooding areas appear on the flood insurance rate maps as AO zones with depth designations. The base flood depths in these zones range from one to three feet where a clearly defined channel does not exist, or where the path of flooding is unpredictable and where velocity flow may be evident. Such flooding is usually characterized as sheet flow. In these areas, the following provisions apply:

- i. New construction and substantial improvements of residential structures within AO zones shall have the lowest floor, including basement or crawl space, elevated above the highest adjacent grade of the building site, to at least one foot above the depth number specified on the flood insurance rate map (at least two feet if no depth number is specified).
- ii. New construction and substantial improvements of nonresidential structures within AO zones shall either:
 - (A) Have the lowest floor, including basement, elevated above the highest adjacent grade of the building site, to at least one foot above the depth number specified on the flood insurance rate map (at least two feet if no depth number is specified); or
 - (B) Together with attendant utility and sanitary facilities, be completely floodproofed to or above that level so that any space below that level is watertight with walls substantially impermeable to the passage of water and with structural components having the capability of resisting hydrostatic and hydrodynamic loads and effects of buoyancy. If this method is used, compliance shall be certified by a registered professional engineer or architect.
- iii. Adequate drainage paths are required around structures on slopes to guide floodwaters around and away from proposed structures.

8. Flood Hazard Permit

a. Required

No person shall engage in development within the flood hazard area unless a flood hazard permit is first issued, pursuant to section 21.03.090, *Flood Hazard Permits*.

b. Conditions

Special conditions may be attached as a condition to the issuance of a flood hazard permit. Conditions shall include any floodproofing measures deemed necessary by the issuing official to further the purposes of this chapter. Floodproofing measures may include requirements that:

- i. The finished surface of the first or main floor shall be at least one foot above the level of the regulatory flood protection elevation.
- ii. Structures or uses below the level of the regulatory flood shall be restricted to those not involving habitual human habitation, such as working space, living space, sleeping space, etc.
- iii. The anchorage shall be suitable to resist flotation and lateral movement.
- iv. For all construction and substantial improvements, fully enclosed areas below the lowest floor that are subject to flooding shall be designed to automatically equalize hydrostatic flood forces on exterior walls by allowing for the entry and exits of floodwaters. Designs for meeting this requirement must either be certified by a registered professional engineer or architect or must meet or exceed the following minimum criteria: A minimum of two openings having a total net area of not less than one square inch for every square foot of enclosed area subject to flooding shall be provided to FEMA specifications. The bottom of all openings shall be no higher than one foot above grade. Openings may be equipped with screens, louvers or other coverings or devices provided that they permit the automatic entry and exits of floodwaters.
- v. All areas below the level of the regulatory flood protection levels shall be coated with paint, membranes, or mortars substantially impermeable to the passage of water.
- vi. Water supply and waste treatment systems must prevent infiltration of water.
- vii. All interior drains must be connected to the sanitary sewer system.

9. Nonconforming Uses

A structure or the use of a structure or premises located within the flood hazard area that was lawful before the original passage of applicable regulations, but that is not in conformity of the provisions of such regulations, may be continued subject to the following conditions:

- a. No such use shall be expanded, changed, enlarged, or altered in any way which increases its nonconformity with respect to the provisions of this chapter.
- b. If such use is discontinued for 12 consecutive months, any future use of the structure or premises shall conform to this chapter.
- c. Uses or adjuncts thereof which are or have become nuisances shall not be entitled to continuance as nonconforming uses.
- d. Any permitted alteration, addition, or repair to any nonconforming structure the cost of which equals or exceeds 50 percent of the fair market value of the structure

which would result in substantially increasing the flood damage potential shall be adequately floodproofed in accordance with subsection 8.b.

10. Duties of the Director of the Public Works Department

- a.** The director of the public works department shall grant or deny development permit applications in accordance with the provisions of this chapter, except that the platting board is directed and authorized to consider this chapter in relation to any matter brought before that board.
- b.** The director of the public works department shall maintain all records required by the Federal Insurance Administration and shall file an annual report with the federal insurance administrator.
- c.** Additional duties and responsibilities of the director of the public works department are as follows:
 - i.** *Permit Review*
The director of the public works department shall:
 - (A)** Review all flood hazard permits to determine that the permit requirements of this chapter have been satisfied.
 - (B)** Review all flood hazard permits to determine that all necessary permits have been obtained from those federal, state, or local governmental agencies from which prior approval is required.
 - (C)** Review all flood hazard permits to determine if the proposed development is located in the floodway, and, if located in the floodway, ensure that the encroachment provisions of subsection 6.a. above are met.
 - ii.** *Use of Other Base Flood Data*
When base flood elevation data have not been provided in accordance with subsection E.4. above, the director of the public works department shall obtain, review and reasonably utilize any base flood elevation data available from a federal, state or other source in order to administer subsections E.6. through E.9. above.
 - iii.** *Information to be Obtained and Maintained*
The director of the public works department shall:
 - (A)** Obtain and record the actual elevation, in relation to mean sea level, of the lowest habitable floor, including basement, of all new or substantially improved structures, and whether or not the structure contains a basement.
 - (B)** For all new or substantially improved floodproofed structures:
 - (1)** Verify and record the actual elevation, in relation to mean sea level; and
 - (2)** Maintain the floodproofing certifications required in subsection 7.a.iv. above.
 - (C)** Maintain for public inspection all records pertaining to the provisions of this section.
 - iv.** *Duties Regarding Alteration of Watercourses*
The director of the public works department shall:

- (A) Notify adjacent communities and the state coordinating agency prior to any alteration or relocation of a watercourse and submit evidence of such notification to the Federal Insurance Administration.
- (B) Require that maintenance is provided within the altered or relocated portion of the watercourse so that the flood-carrying capacity is not diminished.

v. *Interpretation of FIRM Boundaries*

The director of the public works department shall make interpretations, where needed, as to exact location of the boundaries of the areas of flood hazard, for example, where there appears to be a conflict between a mapped boundary and actual field conditions. The person contesting the location of the boundary shall be given a reasonable opportunity to appeal the interpretation as provided in subsection E.11. below.

11. Appeal Procedure

Appeals alleging error by the director of the public works department charged with the enforcement or interpretation of this chapter may be taken to the zoning board of examiners and appeals in accordance with the provisions of section 21.03.050, *Appeals*.

12. Standards and Conditions for Variances and Appeals

- a. In passing upon variances or appeals, the zoning board of examiners and appeals shall consider all technical evaluations, all relevant factors, standards specified in other sections of this section and:
 - i. The danger that materials may be swept onto other lands to the injury of others;
 - ii. The danger to life and property due to flooding or erosion damage;
 - iii. The susceptibility of the proposed facility and its contents to flood damage and the effect of such damage on the individual owner;
 - iv. The importance of the services provided by the proposed facility to the community;
 - v. The necessity of the facility of a waterfront location, where applicable;
 - vi. The availability of alternative locations for the proposed use which are not subject to flooding or erosion damage;
 - vii. The compatibility of the proposed use with existing and anticipated development;
 - viii. The relationship of the proposed use to the comprehensive plan and floodplain management program for that area;
 - ix. The safety of access to the property in time of flood for ordinary and emergency vehicles;
 - x. The expected heights, velocity, duration, rate of rise and sediment transport of the floodwaters and the effects of wave action, if applicable, expected at the site; and
 - xi. The costs of providing governmental services during and after flood conditions, including maintenance and repair of public utilities and facilities such as sewer, gas, electrical and water systems and streets and bridges.

- b. Generally, variances may be issued for new construction and substantial improvements to be erected on a lot of one-half acre or less in size contiguous to and surrounded by lots with existing structures constructed below the base flood level, providing the items in subsections 12.a.i. through xi. of this section have been fully considered. As the lot size increases beyond one-half acre, the technical justification required for issuing the variance increases.
- c. The zoning board of examiners and appeals may attach such conditions to the granting of variances or appeals as it deems necessary to further the purposes of this chapter.
- d. The director of the public works department shall maintain the records of all variance and appeal actions and report any variances to the Federal Insurance Administration upon request.
- e. Conditions for variances are as follows:
 - i. Variances may be issued for the reconstruction, rehabilitation, or restoration of structures listed on the national register of historic places or the state inventory of historic places, without regard to the procedures set forth in the remainder of this section.
 - ii. Variances shall not be issued within any designated floodway if any increase in flood levels during the basic flood discharge would result.
 - iii. Variances shall only be issued upon a determination that the variance is the minimum necessary, considering the flood hazard, to afford relief.
 - iv. Variances shall only be issued upon:
 - (A) A showing of good and sufficient cause;
 - (B) A determination that failure to grant the variance would result in exceptional hardship to the applicant; and
 - (C) A determination that the granting of a variance will not result in increased flood heights, additional threats to public safety, or extraordinary public expense, create nuisances, cause fraud on or victimization of the public, or conflict with existing local laws or ordinances.
 - v. Any applicant to whom a variance is granted shall be given written notice that the structure will be permitted to be built with a lowest floor elevation below the base flood elevation and that the cost of flood insurance will be commensurate with the increased risk resulting from the reduced lowest floor elevation.

(AO 2012-124(S), 2-26-13; AO 2013-117, 12-3-13; AO 2016-34(S), 4-12-16; AO 2017-11, 2-14-17; AO 2018-67(S-1), 10-9-18; AO 2023-77, 7-25-23)

21.07.030 PRIVATE OPEN SPACE

A. Purpose

- 1. In residential development, private open space is intended to provide residents with opportunities for active and passive outdoor recreation, relaxation, and enjoyment. Specific residential objectives of this section include:
 - a. Integrate usable open space into the project design and site plan.
 - b. Enhance the livability and value of new developments in existing neighborhoods.

- c. Create attractive spaces that invite outdoor stays, physical activity, and social interaction, such as gardening, children’s play, barbeques, etc.
 - d. Retain vegetated spaces on site and connect to natural surroundings or scenic views where they may exist off site.
 - e. Provide residents with space for their private or common use that is immediately accessible from their residences, and under their surveillance and sense of proprietorship.
2. In nonresidential development, private open space is intended for the general quality of the public domain, and to provide employees and customers with space for active or passive recreation and relaxation.

B. Applicability and Open Space Requirement

Development shall be required to set aside private open space according to the following minimum requirements.

1. General: For townhouse-style structures, the required open space may be provided as either individual or common private open space, except where common open space is required in subsection 21.07.110E.2. For multifamily-style construction, at least half the required open space shall be provided as common private open space, and no individual private open space is required. Required open space for residential uses shall not be combined with required open space for nonresidential uses.
2. R-2M districts: 200 square feet of private open space per dwelling unit, or an area equal to five percent of the gross floor area of group living uses or nonresidential development.
3. R-3 and R-3A districts: 125 square feet of private open space per dwelling unit. Group living uses and nonresidential development shall provide an area equal to five percent of the gross floor area for open space.
4. R-4 and R-4A districts: 50 square feet of private open space per dwelling unit. Group living uses and nonresidential development shall provide an area equal to five percent of the gross floor area for open space.
5. B-1A, B-1B, B-3, RO, and nonresidential development in residential districts:
 - a. Private open space equal to five percent of the gross floor area of the nonresidential portion of the development shall be provided, up to a maximum requirement of 2,000 square feet.
 - b. Where dwelling units are part of the development, an additional 50 square feet of private open space per dwelling unit shall be provided.

C. Exemptions

The following are exempt from the private open space requirement:

1. Single-family, two-family, multifamily dwellings with less than five units, mobile home, and townhouse residential uses;
2. Parks, Public Safety Facility, Transportation Facility, Utility Facility, Telecommunication Facility, Agricultural Uses, Animal Boarding, Large Domestic Animal Facility;
3. Vehicles and Equipment, Manufacturing and Production, Warehouse and Storage, and Waste and Salvage use categories;

4. Any building floor area devoted to parking and/or loading;
5. Any building floor area provided as indoor private open space that meets the standards of subsection D.3. below; and
6. Any nonresidential building with less than 5,000 square feet of gross floor area.
7. Residential development within one-quarter mile of a public school or dedicated parkland.

D. Standards

1. Areas Not Credited

Lands within the following areas shall not be counted towards required private open space areas:

- a. Setbacks with slopes over 10 percent;
- b. Swales with side slopes over 10 percent, and drainage ditches;
- c. Required site perimeter (except as specifically allowed below) and parking lot landscaping;
- d. Public or private streets or street rights-of-way;
- e. Parking facilities, driveways, other motor vehicle circulation areas, loading areas, and refuse collection areas, except as provided in subsection 21.07.060G.23., *Shared Parking Courtyards*; and
- f. Land covered by structures not intended solely for recreational uses.

2. Private Open Space Areas

In accordance with various open space requirements in subsection B. above, some required open space may be allocated to individual units (individual private open space) and some must be common to all residents/employees/visitors (common private open space).

a. Individual Private Open Space

- i. Required private open space may be private yard, garden, patio, deck, balcony, or other open space reserved for the exclusive use of a single dwelling unit. It shall be designed for the occupants of a specific dwelling, and provided immediately adjacent to, and with direct access from the dwelling.
- ii. The minimum inside dimension for such an area used to meet the private open space requirement shall be no less than 15 feet for ground level spaces such as yards, or four feet for upper story spaces such as balconies. The 15-foot dimension may be reduced by three feet where abutting required site perimeter landscaping on the site, as long as the open space and the landscaping are not separated by a fence or other separating feature.
- iii. An unenclosed porch, deck, or stoop, that is a minimum of 60 square feet in area and at least 24 inches above the adjacent finished grade may be counted as individual private open space for the unit to which it is attached.
- iv. Individual private open space for the exclusive use of each dwelling unit shall have a slope of 10 percent or less.

- v. Private open space shall be separated from refuse collection areas by L1 visual enhancement landscaping.

b. Common Private Open Space

Private open space areas to be used in common by residents and/or associated with nonresidential uses or mixed uses are intended to be usable spaces that incorporate user amenities facilitating passive or active recreation and relaxation. These areas shall meet the following standards:

- i. At least half of the required common private open space shall be contiguous, up to a maximum of 3,000 square feet.
- ii. The minimum inside dimension for an area used to meet the requirement shall be 15 feet for residential uses and 12 feet for nonresidential uses. This dimension may be reduced by three feet where abutting required site perimeter landscaping on the site, as long as the open space and the landscaping are not separated by a fence or other separating feature.
- iii. Common private open space may include lawn areas; picnic areas; gardens; natural vegetation; snow storage areas; equipped recreation areas; sports courts; hard surfaced pedestrian spaces such as patios, decks, courtyards, housing courtyards, or plazas; indoor private open space pursuant to D.3. below; and/or roof tops or terraces.
- iv. Up to 25 percent of the total required open space area may be developed for active recreation, such as with play equipment or delineated sports field.
- v. Private open space shall be separated from refuse collection areas by L1 visual enhancement landscaping.

3. Indoor Private Open Space Option

Up to 25 percent of the total required private open space for residential uses, and up to 50 percent of the total required private open space for nonresidential uses, may be indoors. Such space:

- a. Shall be located and designed to maximize daylight access by providing one square foot of transparent window and/or skylight area for each two square feet of floor area of the indoor private open space;
- b. Shall be climate controlled and furnished with features and amenities that encourage its use;
- c. Shall be available and accessible to all residents, or to all employees and customers of the development;
- d. May include areas such as common recreation areas, fitness facilities, common meeting spaces, seating areas, swimming pools, spas, and hot tubs; and
- e. Shall not be combined with some other function, such as laundry or storage.

4. Incentive for High Quality Spaces

The total open space area requirement may be reduced by 25 percent if the largest common open space area meets all the other requirements of this section and the following standards:

- a. Has less than an average five percent slope;
- b. Is well-drained and not wetlands;

- c. Has a minimum inside dimension of 23 feet for residential uses, or 20 feet for nonresidential uses; and
- d. Receives sunlight access on the majority of the open space for at least four hours per day between the spring and fall equinox.

5. Ownership

All private open space areas not reserved for the exclusive use of a single dwelling unit shall be owned jointly or in common by the owners of the development or permanently preserved through some other mechanism satisfactory to the director. While private open space may be platted into separate tracts, those tracts which provide required private open space shall not be sold separately from the development.

6. Fee In Lieu Prohibited

The payment of fees in lieu of the set-aside of land for private common open space is prohibited.

(AO 2012-124(S), 2-26-13; AO 2013-117, 12-3-13; AO 2015-100, 10-13-15; AO 2017-176, 1-9-18; AO 2020-38, 4-28-20; AO 2023-43, 4-25-23; AO 2023-77, 7-25-23; AO 2023-103(S), 12-18-23; AO 2024-16, 2-27-24)

21.07.040 DRAINAGE, STORM WATER TREATMENT, EROSION CONTROL, AND PROHIBITED DISCHARGES

A. Purpose

1. Drainage plans and the requirements of this section and the *Design Criteria Manual* are intended to implement the following principles of drainage planning:
 - a. The design of a drainage system shall not transfer a problem from one location to another.
 - b. Adequate space shall be provided for drainage conveyance and storage.
 - c. Good drainage design incorporates the effectiveness of the natural systems, rather than negating, replacing, redirecting, or ignoring them. The features, capacity, and function of the existing natural system shall be considered and utilized.
 - d. Drainage and storm water management facilities shall be designed with ease of maintenance, long-term function, sub-arctic climate function, protection of public safety, and accessibility as primary considerations.
2. Other purposes of this section include:
 - a. Regulating development preparation and land-disturbing activity in order to control erosion and sedimentation and accordingly to prevent water pollution from sedimentation, to prevent accelerated erosion and sedimentation of lakes and natural watercourses; and to prevent damage to public and private property by erosion and/or sedimentation during and after construction;
 - b. Regulating storm water discharge to improve the quality of the environment for residents of the municipality, administer the Municipal Separate Storm Sewer permit, and manage impacts to the watersheds in the municipality; and
 - c. Minimizing point and non-point source pollution into the water bodies of the municipality.

B. Guidance Documents

The municipal engineer shall develop, implement, and maintain various guidance manuals which shall provide standards and guidelines for this section 21.07.040. The *Design Criteria Manual* and the *Storm Water Treatment Plan Review Guidance Manual* are examples of such manuals.

C. Emergencies

Where site work deviates from approved plans due to an emergency, the municipal engineer shall be notified on the next business day. Changes to an approved plan shall be submitted within 14 days to the public works department. For the purposes of this section, an “emergency” is a situation which would result in an unacceptable hazard to life, a significant loss of property, or an immediate, unforeseen, and significant economic hardship if corrective action requiring a permit is not undertaken immediately.

D. Drainage**1. Intent**

A drainage plan shall show the post-development drainage patterns of the site.

2. Applicability

This section applies to all development within the municipality.

3. Drainage Plan Required

a. Applications for the following entitlements shall include a drainage plan:

- i. A permit from the development services department, for projects that include land disturbance;
- ii. Subdivision plat (both preliminary and abbreviated plats);
- iii. Site plan review (administrative and major); and
- iv. Conditional use.

The drainage plan submittal requirement may be waived by the director and the municipal engineer if both agree that such a plan is not necessary.

b. The drainage plan shall show the area affected by the application, as well as watercourses, drainage and water quality easements, appropriate drainage outfall for surface water, roof drainage, and other impervious surfaces, and any other pertinent information, and shall address surface and subsurface drainage. The drainage plan shall also indicate impacts, if any, on adjacent, up-gradient, and down-gradient properties.

c. An approved drainage plan is required before any site work commences.

4. Standards

Drainage plans shall comply with the requirements of municipal code and the guidance of the *Design Criteria Manual*. Post-development drainage plans shall be designed in a manner such that there will be no adverse off-site impacts. Any net increase of water volumes shall be mitigated and/or directed to an adjacent drainage system or receiving water that has the demonstrated capability to handle the new flows. The municipality may require a dedicated drainage easement(s) to ensure the drainage is consistent and compatible with surrounding drainage patterns.

5. When No Permit is Required

a. In situations where a building or land use permit is not required, all design and construction activities shall comply with municipal code.

- b. If the municipal engineer reasonably believes that a project is significant in nature or that it will have negative impacts on surrounding property, water quality, drainage, or the roadways, the municipal engineer may require submittal of a drainage plan and a full review of the project. The applicant shall pay the appropriate review fees for the review. If the project is under construction, the municipal engineer may issue a stop work order until the project has been reviewed and approved.
- c. If a project has been completed and there are negative impacts on surrounding property, water quality, drainage, or the roadways, the municipal engineer may pursue enforcement actions under chapter 21.14.

6. Exposure of Subsurface Flows

If, during site work, unexpected subsurface flows are exposed, the municipality shall be informed immediately. If the subsurface flow cannot be contained within the site and has a significant off-site impact, work shall cease immediately and shall not be resumed until a temporary flow management plan has been submitted to and accepted by the municipality. In addition, the developer shall amend the drainage plan to address the exposed flows and potential for glaciation and shall submit it to the municipality and receive approval before resuming site work other than temporary flow management.

E. Storm Water Treatment and Erosion and Sediment Control

1. Intent

A storm water treatment plan shall show both the controls put in place during construction and any needed post-development controls to prevent erosion and protect water quality.

2. Applicability

Storm water treatment plan approval is required prior to commencement of land clearing or ground disturbing activities; the discharge of surface water (including from snow disposal sites); the construction, alteration, installation, modification, or operation of a storm water treatment or disposal system; demolition or utility work; connection to the municipal separate storm sewer system; work in water bodies, wetlands, or watercourses; or dewatering activities, except as listed in E.4. below. All construction, development, and maintenance activities shall be in accordance with the approved storm water treatment plan.

3. Nonconformities

No nonconforming rights are granted for this section 21.07.040E.

4. Exceptions

A storm water treatment plan shall not be required for the following. An erosion control plan may still be required if the discharge is so concentrated as to cause soil disturbance. The municipal engineer may waive the requirement for a storm water treatment plan for other activities that, in his or her judgment, will not create erosion or impair water quality.

- a. Building improvements where no earth is disturbed;
- b. Any earth disturbance that is less than 500 square feet in area;
- c. Agricultural activities (not including site landscaping). Discharges from agricultural activities are still subject to water quality standards and potential enforcement for illicit discharges to watercourses or the storm sewer system;
- d. Discharges of the following into the municipal separate storm sewer system:
 - i. Uncontaminated water line flushing;
 - ii. Residential irrigation water;

- iii. Rising ground waters;
- iv. Uncontaminated ground water infiltration;
- v. Uncontaminated discharges from potable water sources;
- vi. Foundation drains;
- vii. Air conditioning condensate;
- viii. Springs;
- ix. Uncontaminated water;
- x. Individual residential car washing;
- xi. Flows from riparian habitats and wetlands;
- xii. De-chlorinated swimming pool discharges;
- xiii. Street wash waters; or
- xiv. Flows from emergency firefighting activity.

5. Submittal Requirements and Review Procedure

Storm water treatment plans shall be submitted to the public works department on the form provided. The submittal shall include plans for both temporary (during construction) and permanent storm water treatment and erosion control, and any supplementary information required in the *Design Criteria Manual*.

a. Storm Water Treatment Plan Review Guidance Manual

The *Storm Water Treatment Plan Review Guidance Manual* shall be used to develop, review, and approve storm water treatment plans. Applicants submitting plans under this subsection shall comply with the manual regarding plan requirements and reviews, and if necessary shall gather data to confirm storm water conditions.

b. Changes to an Approved Storm Water Treatment Plan

Any changes to permanent storm water controls from an approved storm water treatment plan require approval by the municipal engineer. Changes in temporary or construction storm water treatment controls or best management practices necessary to maintain effective storm water treatment do not require municipal approval but shall be documented.

c. New Application Required

If dewatering, land clearing, construction, alteration, installation, modification, or operation has not begun within one year after issuance of a storm water treatment plan approval, the approval is void, and a new application shall be submitted to the public works department for review and approval.

d. Project-Wide Approval

The municipal engineer may issue a project-wide approval to an applicant who plans to conduct an operation with the same runoff characteristics at various discharge locations. He or she may require the submittal of site-specific plans, including a schedule and description of all planned discharge activities, for approval, and may restrict that approval to certain proposed discharge activities.

6. Land Clearing

Mechanized land clearing of one acre or greater requires an approved storm water treatment plan. Until a subsequent use is approved, a temporary native vegetation buffer shall be retained on the perimeter of the lot being cleared, equal to or greater than the specified minimum setback required in the zoning district. This buffer shall be at least 15 feet wide on the perimeter of lots in commercial and industrial zoning districts, except where these are adjacent to PLI and/or residential zoning districts, where the temporary buffer shall be a minimum of 30 feet wide. Those areas of native vegetation in commercial and industrial zoning districts not essential to the parcel's development and situated on the perimeter of the site shall be retained and protected from disturbance as specified in subsection 21.07.080F.3.

7. Erosion and Sediment Control Administrator

A qualified erosion and sediment control administrator, who shall be responsible for the erosion, sedimentation, and best management practices during construction, shall be identified in each storm water treatment plan submitted for approval, except for storm water treatment plans for owner-built single- and two-family dwellings. Evidence of contractual liability shall be provided when requested.

a. In order to be identified as a qualified administrator, a person shall successfully complete a training course and associated test for certification from a training program approved by the public works department.

b. The qualified administrator shall maintain their certification in active status throughout the length of the project. In the case where the qualified administrator's certification becomes expired or revoked, a new qualified person shall be selected to be the erosion and sediment control administrator and shall be identified on the storm water treatment plan.

8. Alternate Materials, Design, and Method of Construction

a. The provisions of this section are not intended to prevent the use of any alternate material, design, or method of construction not specifically prohibited by this code, provided any alternate has been approved and its use authorized by the municipal engineer.

b. The municipal engineer may approve any such alternate, provided that he or she finds that the proposed design complies with the intent and purpose of this code, and that the material, method, or work offered is, for the purpose intended, at least the equivalent of that required in this code in suitability, effectiveness, durability, safety, sanitation, and degree of structural integrity. The details of any action granting modifications or the acceptance of a compliance alternative shall be recorded and entered in the public works department's files.

c. Whenever there is insufficient evidence of compliance with any of the provisions of this code or evidence that any material or construction does not conform to the requirements of this code, the municipal engineer may require tests as proof of compliance to be made at no expense to the municipality. Test methods shall be as specified by this code or by other recognized test standards. If there are no recognized and accepted test methods for the proposed alternative, the municipal engineer shall determine test procedures. All tests shall be made by an approved agency. Reports of such tests shall be retained by the municipal engineer for the period required for the retention of public records.

9. Inspections**a. Required Inspections**

Prior to the commencement of or during land clearing or ground disturbing activities of one acre or greater, the discharge of surface water, or dewatering

activities subject to this section, an inspection of approved best management practices associated with the storm water treatment plan shall be conducted. Prior to the issuance of a certificate of zoning compliance, permanent site controls shall be verified by inspection or other means, as determined by the municipal engineer. The owner or contractor of record is responsible for requesting the required inspections at the appropriate times.

b. Other Inspections Authorized

- i. A municipal official, upon presentation of proper identification, may enter the premises at reasonable times to inspect or perform duties imposed by this code, for the purpose of determining whether the owner or operator thereof is in compliance with the specific requirements of this section. If such premises are unoccupied, the official shall first make a reasonable effort to locate the owner or other person having charge or control of the premises and request entry. If entry is refused, any approvals issued under this section may be immediately suspended until an inspection is conducted, and the official shall have recourse to the remedies provided by law to secure entry. Permittees, owners, or operators shall immediately stop all work upon the site being posted with a stop work order for failure to allow inspection.
- ii. A municipal official may inspect any property or facility suspected as the source of illicit discharges in violation of 33 USC 1342 (1987) as amended.
- iii. No inspection for which a warrant would be required under the constitution of this state or the United States may be conducted under this section without the proper warrant.

c. Availability and Production of Plans and Records

Approved plans and specifications shall be available on site for review by municipal inspectors at the time of requested inspections. At the request of municipal officials and during normal working hours, owners or operators of facilities, construction sites, premises, or areas shall produce and make available for inspection or copying all records or information required to be maintained or reported under the provisions of this section.

F. Snow Storage and Disposal

1. Intent

This section addresses seasonal storage and management of plowed snow from on-site parking lots and other motor vehicle areas. It requires developments to provide space to accommodate plowed snow, and also allows alternative and innovative solutions. This section is not designed to increase the amount of area already used for snow storage by existing developed residential and commercial property; instead it is intended to clarify applicable regulations and encourage thoughtful site planning and snow management with respect to adjacent property and other requirements of this title. Its objectives are:

- a. Ensure water quality treatment and drainage control of snow melt;
- b. Maintain safe and convenient access and circulation; and
- c. Protect adjacent landscaping, walkways, streets, and property.

2. Applicability

Except where stated otherwise, all existing and new uses with on-site surface areas to be plowed for motorized vehicle access or parking shall comply with this section. For example, this includes surface areas such as parking spaces, circulation and parking aisles, associated driveways, queuing lanes, emergency vehicle access lanes, loading

areas, tractor trailer areas, and vehicle sales and display areas. The following uses and surfaces are exempt:

- a. Single-family, two-family, three-unit multifamily, townhouse, and mobile home dwellings on individual lots;
- b. Snow disposal sites subject to subsection 21.05.060E.8.; and
- c. Ice-free (snow-melting) surfaces and/or covered surfaces.

3. Operational Standards

For all applicable uses (including existing uses and new development):

- a. Plowed snow shall not interfere with required pedestrian or vehicle circulation or sight distance.
- b. Snow storage shall not interfere with access to utility equipment or create a hazard around utility equipment, in accordance with utility tariffs. For example, snow piles shall not be placed underneath an overhead utility line such that the snow pile reduces clearances to less than National Electrical Safety Code (NESC) ground clearance requirements.
- c. Plowed snow may be removed to an approved snow disposal site, or shared among abutting or contiguous lots jointly managed for snow storage and disposal purposes. Plowed snow shall not be otherwise removed from the property. Snow shall not be moved to a right-of-way or other public place without a valid right-of-way permit pursuant to title 24.
- d. Snow piles stored longer than on a 72 hour temporary basis shall not result in direct offsite drainage such as onto neighboring properties or public rights-of-way, except for snow melt drainage directed into an approved drainage facility.
- e. Winter trash accumulation from plowed snow shall be removed and paved snow storage areas swept by June 1 (or as soon as snowmelt conditions permit).

4. Snow Storage Areas on New Development Sites

Developments involving the construction of new principal buildings, the removal and replacement of existing principal buildings, and/or the expansion or redevelopment of on-site surface areas to be plowed for motorized vehicle access and parking shall provide for snow storage and disposal on the site plan, as provided below. Tenant improvements, renovations, alterations, and enlargements of existing developments are exempt, except that the addition or expansion of parking lots or other areas for motorized vehicle parking and access by the greater of either 10 parking spaces or 10 percent of the existing area shall comply.

- a. If snow will be stored on-site, snow storage areas shall be designated on the site plan as provided in 4.b. through 4.g. below. If snow will be removed off-site to a snow disposal facility or another alternative snow management strategy is used as provided in subsection F.5. below, then the snow storage areas may be reduced or eliminated from the site plan.
- b. For residential uses, an area equal to at least 10 percent of the surface area on the site to be plowed for motorized vehicle parking and access (as identified in subsection F.2.) shall be designated for snow storage. For nonresidential uses, this area requirement shall be five percent.
- c. As an alternative to 4.b. above, the applicant shall provide a calculation stamped by a professional registered with the Alaska State Board of Registration for

Architects, Engineers, and Land Surveyors, that indicates the proposed snow storage and disposal strategy will be adequate to accommodate the plowed snow in an average snow year, considering the site plan layout, the amount of surface area to be plowed for motorized vehicles (as identified in subsection F.2.), and the proposed method(s) of snow storage and disposal.

- d. Snow storage areas shall be located to comply with the operation standards of subsection F.3. above, and shall abut the surface area to be plowed.
- e. Snow storage areas shall have a minimum dimension of eight feet to accommodate snow piling from a plow blade.
- f. The site plan shall not, unless allowed through an administrative site plan review, designate snow storage areas in required perimeter landscaping or on required trees. Designation of required residential private open space for snow storage shall be permitted.
- g. Snow storage areas shall be planted with ground-cover (such as grass), or paved subject to subsection 21.07.090H.15., *Paving*.

5. Alternative Snow Management Strategies

Alternative snow management strategies such as snow melters, underground storage, or removal to an approved snow disposal site, may be approved by the municipal engineer in lieu of a required snow storage area, subject to the following:

- a. The owner shall either set aside the area that would otherwise be needed to provide the required snow storage area on the site, or enter into an agreement with the municipality, in conformance with the title 21 user's guide, which is recorded, runs with the use of the land, and ensures continuation of the alternative strategy and the future implementation of contingency measures if such contingency measures are ordered by the municipal engineer.
- b. Areas to be used for temporary storage of plowed snow awaiting removal or disposal shall be depicted on the site plan.
- c. The method of treatment and disposal shall comply with subsection F.8. below.

6. Setbacks

Plowed snow shall be set back from streams, watercourses, wetlands, and water bodies as specified in section 21.07.020, and is prohibited within ten feet of storm water outfalls and discharge points.

7. Snow Melt Drainage

Developments shall comply with subsection 21.07.040D., *Drainage*, to address drainage of snow melt in areas of the site affected by the development.

8. Snow Melt Treatment

Detention and treatment practices and/or facilities for chloride, particulates, and other pollutants shall be provided prior to discharge of snow melt from a site sufficient to comply with subsection 21.07.040E., and shall be subject to review and approval by the municipal engineer.

G. Prohibited Discharges

1. Applicability

This section applies throughout the municipality.

2. Prohibited Discharges or Acts

No person shall cause or permit illicit discharges:

- a. Into any waters of the state, or waters of the United States, unless such is first treated in a manner approved by the federal, state, or other agencies having jurisdiction; or
- b. Into a storm sewer of the municipality, other than pursuant to a dewatering permit, an approved storm water treatment plan, a national pollutant discharge elimination system permit, or a permit issued by a local, state, or other agency having jurisdiction. Examples of discharges that are prohibited include:
 - i. Grease, fatty materials, offal, or garbage;
 - ii. Sand, sand dust, dirt, gravel, sawdust, metal filings, broken glass, or any material which may cause or create an obstruction in the sewer;
 - iii. Gasoline, benzene, fuel oil, or a petroleum product or volatile liquid;
 - iv. Milk or any liquid milk waste product in quantities in excess of ten gallons during any 24-hour period;
 - v. Wax, cyanide, phenols, or other chemical or substance that may cause damage to materials of which the sewer system is constructed; or
 - vi. Wastewater, as defined in AMC section 15.20.010.

For the purposes of this section, "illicit discharges" means pollutants or any materials other than storm water.

3. **Dumping in Watercourses and Water Bodies**

No person shall deposit, dump, abandon, throw, scatter, or transport solid waste, garbage, rubbish, junk, fill, soil, dirt, snow, ice, vegetation, or other material in such a manner as to obstruct, impound, or cause siltation of any river, stream, creek, watercourse, water body, stream or water body or wetland setback, water quality easement, storm sewer, ditch, drain, or gutter except as otherwise allowed by valid federal, state, and other permits or licenses relative to water pollution, water impoundment, or water quality control.

H. **Hazardous Sites**

1. For the purposes of this section, any site meeting any or all of the conditions and defects described below shall be deemed to be hazardous, provided that such conditions or defects exist to the extent that the health of the watershed, the requirements of the Municipal Separate Storm Sewer System permit, or the safety of the public are endangered, as determined by the municipal engineer.
 - a. Any site that causes sediment to be discharged in such a way that it may be delivered directly or indirectly to the storm sewer or receiving waters;
 - b. Any site that causes pollution to be discharged in such a way that they may be delivered to the watershed;
 - c. Any property for which the owner, manager, or tenant fails to install and/or maintain properly permitted BMPs; or
 - d. Any site where actions are causing soil masses to be in danger of sloughing, destabilizing, failing, or collapsing as a mass wasting event.
2. All sites which are determined after inspection by the municipal engineer to be a hazardous shall be abated as determined by the municipal engineer.

I. Violations and Penalties

1. Violations

- a. Any person who violates any provisions of this section shall report such violation to the project management and engineering department and shall make available any information or records related to the contents of the substance discharged.
- b. In addition to any other remedy or penalty provided by this title, any person who violates any provision of this title or regulations adopted there under shall be subject to the civil penalties or injunctive relief, or both, as provided by AMC section 1.45.010B.
- c. In any action under this section, the municipality, if not a party, may intervene as a matter of right.

2. Penalties

- a. All sites operating without approval under this section may be immediately posted with a stop work order and shall pay double fees for all required permits or inspections under this section, as well as any fines which may be assessed. In addition to any other remedy permitted by law, fines may be assessed for failure to have a permit or approved plan, failure to allow inspections, or failure to obey a properly issued stop work order. Violators of this section may also be charged \$1,000 per day until the violation(s) is corrected.
- b. Any person who negligently or intentionally permits or causes a discharge in violation of this section shall, upon conviction, be subject to a civil fine penalty of \$5,000 to \$10,000 per day, or injunctive relief to cease the violation, or both. In addition to any fine assessed under this section, any person who violates any provision of this section or any rule or regulation adopted pursuant to this section shall be subject to a further civil penalty of up to double the cleanup and remediation costs incurred as a result of the violation.
- c. Any person who permits or causes a discharge in violation of this section shall be strictly liable, regardless of intent, for the full amount of any fines or other liquidated penalties incurred by the municipality for any violations of federal law which are caused by the discharge.
- d. No certificate of zoning compliance shall be issued until all fines levied under this section have been paid.

J. Appeals

- 1. Appeals of orders, decisions, or determinations made by the municipal engineer shall be heard by the zoning board of examiners and appeals, pursuant to subsection 21.03.050B.
- 2. The zoning board of examiners and appeals shall have no authority over the interpretation of the administrative provisions of this section, nor shall the board be empowered to waive requirements of this section.

(AO 2012-124(S), 2-26-13; AO 2015-100, 10-13-15; AO 2021-89(S), 2-15-22; AO 2023-103(S), 12-18-23)

21.07.050 UTILITY DISTRIBUTION FACILITIES

A. Underground Placement Required for New or Relocated Lines

- 1. Except as provided in subsection B. below, all newly installed or relocated utility distribution lines (as defined in section 21.15.040) shall be placed underground.
- 2. Utility distribution lines owned or operated by utilities that are parties to a joint trench agreement shall be placed underground in a joint trench.

3. Nothing in this section restricts the maintenance, repair, or reinforcement of existing overhead utility distribution lines.

B. Exceptions

1. Except where an assessment district has been formed to convert overhead utility distribution lines as provided in title 19.60, utility distribution lines need not be placed underground in the class B improvement area defined in subsection 21.08.050B., or in the I-2 zoning district. However, in the following areas newly installed or relocated utility distribution lines shall be placed underground: Lower Hillside, between and including Abbott Road, Rabbit Creek Road, Hillside Drive and the New Seward Highway.
2. Except where an assessment district has been formed to convert overhead utility distribution lines as provided in AMC chapter 19.60, CATV utility distribution lines need not be placed underground where there are other overhead utility distribution lines; provided that, when all of the other overhead distribution lines are placed underground, the CATV utility distribution line shall also be placed underground.
3. A new utility distribution line may be placed overhead when necessary immediately to restore service interrupted by accident or damage by flood, fire, earthquake or weather; provided that the utility distribution line shall be replaced by a utility distribution line conforming to this chapter within 12 months of its placement.
4. A utility distribution line or service connection may be placed on the surface of frozen ground, provided that it is placed underground within 12 months thereafter.
5. New facilities may be added to existing overhead utility distribution facilities located outside target areas.
6. A temporary utility distribution line may be placed overhead in connection with new construction if the utility's tariff approved by the state public utilities commission expressly provides for removal of that line by a date certain, not to exceed 12 months thereafter.

C. Variances

1. The director may grant a variance from subsection A. above when any of the following is found:
 - a. Placing a utility distribution line underground would cause an excessive adverse environmental impact;
 - b. Placing a utility distribution line underground would threaten public health and safety, because the placement cannot be shown to meet acceptable technical standards for safety; or
 - c. Placing a utility distribution line underground in an environmentally sound and safe manner would cost more than three times the cost of placing the line overhead, where the applicant demonstrates the relative cost to the satisfaction of the director.
2. The director may grant a variance from subsection A. above when he or she finds that the utility distribution line is being placed overhead temporarily for one of the reasons listed in this subsection:
 - a. The line is being placed to provide service when weather conditions do not allow excavation for underground placement;
 - b. A permanent location for underground placement is not available because of construction in progress; or

- c. The line is being placed to provide service to a temporary use or structure.

A variance issued under this subsection C.2. shall expire within two years of its issuance.

D. Relationship to Chapter 21.13, *Nonconformities*

Existing overhead utility distribution lines located where this title requires new or relocated utility distribution lines to be placed underground are nonconforming utility distribution lines and are subject to the provisions of this subsection. A utility distribution line is not a nonconforming structure or use under chapter 21.13, *Nonconformities*, solely because it is a nonconforming overhead line under this section.

E. Nonconforming Overhead Lines in Dedicated Municipal Parks

1. When a utility proposes to underground an existing overhead utility distribution line located in a dedicated municipal park, and the overhead and underground alignment are identical, no fee shall be assessed to the utility for the value of the easement.
2. The public works department director may, upon request by a utility:
 - a. Grant an administrative variance from subsection E.1. above, up to five feet on either side of the existing overhead easement center line, to adjust the underground alignment.
 - b. An adjustment exceeding five feet on either side of the existing overhead easement center line shall require a new easement, including assessment of a fee for the value of the easement and administrative costs.
3. The utility shall remain solely responsible for municipal administrative fees and costs associated with the relocation, including but not limited to, a managing department application fee, and document research, review, and preparation.
4. The disposal procedures for interests in municipal land, set out in AMC chapter 25.30, and the variance procedure, set out in subsection C. above, shall not apply to this section.

F. Designation of Target Areas

1. An electric utility that owns poles that support nonconforming utility distribution lines shall prepare or otherwise include as part of its annual capital improvement plan, a five-year undergrounding program consistent with subsection G. below. This five-year program shall be updated on an annual basis. Priorities shall be based on undergrounding in conjunction with the electric utility's essential system improvements and then by target area as set forth below in no particular order of priority. The director shall review and provide comment for consideration by the electric utilities on these five-year programs. When reviewing and commenting on these programs, the director shall consider the following factors in no particular order of priority:
 - a. Whether undergrounding will avoid or eliminate an unusually heavy concentration of overhead distribution facilities.
 - b. Whether the street or general area is extensively used by the general public and carries a heavy volume of pedestrian or vehicular traffic.
 - c. Whether the appearance of grounds and structures adjacent to the roadway is such that the removal of the overhead facilities will substantially improve the general appearance of the area.
 - d. Whether the street or area affects a public recreation area or an area of scenic interest.

- e. Whether there is a significant opportunity to achieve economies due to the anticipated relocation or replacement of overhead lines or the widening or realignment of streets within a given area.
 - f. Whether the five-year program sufficiently addresses the objectives of subsection G. below.
 - g. Whether the area under consideration is within a zone where new and relocated distribution lines are required to be placed underground.
 - h. Whether the installation of underground distribution lines is economically, technically and environmentally feasible, including the effect on the attached utility.
 - i. Whether undergrounding will avoid or eliminate overhead electric distribution or other attached utility facilities in a residential area with significant risk exposure to wildfire, high winds, or other natural disaster.
2. The director shall confirm annually that the electric utilities have developed project undergrounding implementation plans. The director shall consult with the utilities and public agencies affected by any implementation plan. In reviewing implementation plans, the director shall consider the factors stated in subsection F.1. above.
3. The following shall be target areas:
- a. Central Business District: between and including Third Avenue and Tenth Avenue and L Street and Ingra Street.
 - b. Midtown area: between and including New Seward Highway and Minnesota Drive and International Airport Road and Fireweed Lane.
 - c. All municipal and state street improvement projects except for those which do not require relocation of utility distribution facilities.
 - d. The following major traffic corridors:
 - i. Old Seward Highway.
 - ii. Ingra and Gambell Streets between and including Ninth Avenue and Fireweed Lane.
 - iii. Northern Lights Boulevard and Benson Boulevard between and including Glenwood Street and Arlington Drive.
 - iv. Muldoon Road between and including New Glenn Highway and Patterson Street.
 - v. Tudor Road between and including Patterson Street and Arctic Boulevard.
 - vi. Boniface Parkway between and including 30th Avenue and New Glenn Highway.
 - vii. Spenard Road between and including Hillcrest Drive and International Airport Road.
 - viii. Arctic Boulevard between 17th Avenue and Tudor Road.
 - ix. Lake Otis Parkway between Tudor Road and Abbott Loop
 - e. All park, recreational use, and scenic interest areas.

- f. Eagle River Central Business District between and including the New Glenn Highway, North Eagle River Access Road, Aurora Street as extended to the Old Glenn Highway, and the Old Glenn Highway.
- g. Any area where utility distribution facilities are provided by more than one utility as a result of mergers and boundary changes approved by the state public utilities commission.
- h. School and university areas.
- i. Any residential area with significant risk exposure to wildfire, high winds, or other natural disaster.

G. Nonconforming Overhead Lines

1. An electric utility that owns poles that support nonconforming utility distribution lines shall remove the poles and place those lines underground. Any other utility that attaches to such poles shall place its lines underground at the same time that the pole owner places lines underground.
 - a. The electric utility that owns poles shall, in each fiscal year, expend at least two percent of a three-year average of its annual gross retail revenues derived from utility service connections within the municipality, excluding toll revenues, revenues from sales of natural gas to third parties, and revenues from sales of electric power for resale for purposes of undergrounding nonconforming lines. An electric utility's expenditures, pursuant to AS 42.05.381(h), within the municipality, shall be counted toward satisfaction of the two percent expenditure required by this subsection.
 - b. A utility with lines attached to a pole that is to be removed under this subsection shall place its lines underground at the same time that the pole owner places its lines underground. To underground nonconforming utility lines, an attached utility shall not be required to expend more than two percent of its annual gross retail revenues derived from utility service connections within the municipality, excluding toll revenues. For the purpose of satisfying subsection 21.07.050G., the utility's expenditures pursuant to AS 42.05.381(h) within the municipality are counted toward this two percent expenditure limit.
 - c. The electric utility that owns poles may choose which existing lines to underground in order to fulfill the two percent expenditure requirement, in consultation with appropriate public agencies and any other utilities.
 - d. An electric utility that owns poles that does not expend the amount required in subsection G.1. of this section, or that expends more than that amount, may carry over the under expenditure or over expenditure as an adjustment to the following year's obligation.
2. The electric utility that owns poles shall notify the director, and utilities or entities with lines attached to such poles, of the approximate date that the owner plans to remove the poles. Such notice, where possible, shall be given at least four months in advance of the undergrounding except where an emergency or other unforeseen circumstances preclude such notice, in which case such advance notice as is reasonable under the circumstances shall be provided.
3. A utility shall annually submit a report of its undergrounding projects and expenditures for non-conforming lines to the director within 120 days of the end of the preceding calendar year.

4. All new service connections shall be placed underground in the same manner as required for utility distribution lines under subsections A. and B. above. New service lines may be temporarily installed above ground from October through May, if placed underground prior to the next October.

H. Lines in Municipal Right-of-Way

1. The department of public works shall furnish to a utility owning or operating utility distribution lines all planning documents for municipal road construction that will require the relocation of those utility distribution lines.
2. Once a utility installing a utility distribution line underground in material compliance with a right-of-way permit issued by the department of public works and in accordance with this chapter, the municipality shall reimburse the cost of any subsequent relocation of the utility distribution line required by municipal road construction.
3. If municipal road construction requires the relocation of a nonconforming utility distribution line, the municipality, as part of the road construction project cost, shall reimburse the cost of the relocation. Reimbursable costs under this subsection include engineering and design, inspection, construction, and general overhead costs, but exclude utility plant betterment costs. Plant betterment costs are the costs of providing utility distribution line capacity or quality beyond what current industry standards require for the capacity or level of service existing before the relocation.

I. Conversion of Service Connections

A utility that places a nonconforming utility distribution line underground as required by subsection G. above shall bear the cost of placing underground any related service connections or other utility facilities on a customer's premises, in accordance with the utility's applicable tariff or rules or regulations of operation.

J. Landscaping

A utility shall provide written notice to property owners about planned projects that affect landscaping within utility easements.

(AO 2012-124(S), 2-26-13; AO 2013-117, 12-3-13)

21.07.060 TRANSPORTATION AND CONNECTIVITY

A. Purpose

The purpose of this section 21.07.060 is to support the creation of a safe and highly connected transportation system within the municipality in order to provide choices for drivers, bicyclists, and pedestrians; increase effectiveness of municipal service delivery; promote walking and bicycling; connect neighborhoods to each other and to local destinations such as employment, schools, parks, and shopping centers; reduce vehicle miles of travel and travel times; improve air quality; reduce emergency response times; support the pattern of designated land uses; mitigate the traffic impacts of new development; create road and trail connectivity to free up arterial capacity while protecting neighborhood identity and safety; and, in high-volume traffic corridors, maintain an adequate degree of crossings for local circulation and minimize road and traffic impacts on adjacent uses.

B. Applicability

The standards of this section 21.07.060 shall apply to all development in the municipality.

C. Traffic Impact Mitigation

1. Traffic Impact Analysis Required

The transportation system for new development shall be capable of supporting the proposed development in addition to the existing uses in the area. Evaluation of system capacity shall be undertaken through a traffic impact analysis (TIA), which should consider the following factors without limitation: street capacity and level of service; vehicle access and loading; on-street parking impacts; the availability of transit service and connections to transit; impacts on adjacent neighborhoods; and traffic safety including pedestrian safety. Unless the traffic engineer issues a substantiated written finding, based on location of the project and professional judgment, that there is no need for a TIA, a traffic impact analysis (TIA) shall be required with applications for development review and approval when:

- a. Thresholds established in the traffic department's *Policy on Traffic Impact Analyses* are met;
- b. A TIA is required by the planning and zoning commission or assembly as a condition of any land use application approved pursuant to the requirements of this title;
- c. Any case where the traffic engineer determines that the previous TIA for the property is out of date and no longer accurate—in such case the TIA shall not be less than two years old;
- d. Any case where increased land use intensity will result in substantially increased traffic generation or reduction of the existing level of service on affected streets by at least one service level; or
- e. Any case in which the traffic engineer determines that a TIA should be required because of other traffic concerns that may be affected by the proposed development.

2. TIA and Development Review Process

- a. Prior to the development of a required TIA, there shall be a scoping meeting that includes the traffic department, the applicant, and all other relevant parties.
- b. The development and review of a TIA shall be according to the traffic department's *Policy on Traffic Impact Analyses*.

- c. When state-owned roads are involved, the applicant shall coordinate with the state department of transportation and public facilities, and the development of a TIA shall follow state regulations as defined in 17 AAC 10.095.

3. Traffic Mitigation Measures

The applicant shall, as part of the traffic impact analysis, recommend measures to minimize and/or mitigate the anticipated impacts and determine the adequacy of the development's planned access points. Mitigation measures shall be acceptable to the traffic engineer and may include, without limitation: an access management plan; transportation demand management measures; a reduction in the intensity or size of the proposed development; street improvements on or off the site; phasing of the proposed development to coincide with, and not outpace, the necessary upgrades to off-site infrastructure; placement of pedestrian, bicycle, or transit facilities on or off the site; or other capital improvement projects such as traffic calming infrastructure or capacity improvements.

D. Streets and On-Site Vehicular Circulation

1. Street Standards

All streets shall meet the standards and requirements set forth in subsections 21.08.030F.2., *Street Grades*, 21.08.030F.4., *Street Alignment*, and 21.08.030F.5. *Street Intersections*.

2. Parking Lots

In addition to complying with the standards in this subsection 21.07.060D., parking lots shall comply with the standards set forth in section 21.07.090, *Off-Street Parking and Loading*.

3. Street Connectivity

a. Purpose

Street and block patterns should include a clear hierarchy of well-connected streets that distribute local traffic over multiple streets, providing multiple direct connections for neighborhood residents to and between local destinations, and avoid traffic congestion on principal routes. Within each residential development, the access and circulation system should accommodate the safe, efficient, and convenient movement of vehicles, bicycles, and pedestrians through the development; provide ample opportunities for linking adjacent neighborhoods, properties, and land uses; and be designed in such a way as to limit and discourage cut-through traffic and protect the new development and adjacent development from adverse impacts. This section is not intended to increase speed limits in neighborhoods, create opportunities for cut-through traffic, or encourage freight movement through residential areas.

b. Internal Street Connectivity

- i. Developments, whether subdivisions or not, shall meet the block length requirements of subsection 21.08.030G.
- ii. Whenever cul-de-sac streets are created, at least one 10 foot wide pedestrian access right-of-way or easement shall be provided, to the extent reasonably feasible, between each cul-de-sac head or street turnaround and the closest adjacent street or pedestrian walkway. This requirement shall not apply where it would result in damage to or intrusion into significant natural areas such as stream corridors, wetlands, and steep slope areas, or if the configuration of existing adjacent development prevents such a connection.

c. External Street Connectivity

- i. The arrangement of streets in a development shall provide for the alignment and continuation of existing streets from the boundaries of the

development. The arrangement of streets shall provide connections to adjacent lands that are undeveloped and intended for future development as required in subsection 3.e. below, or that are developed and include opportunities for such connections. This arrangement may be reduced or waived by the decision-making body if the applicant can show how connectivity is provided by a different arrangement of streets. Vehicular and/or pedestrian connections to adjacent municipal parks or municipal lands designated as parks shall be required unless waived by the director of the parks and recreation department.

- ii. Street rights-of-way shall be extended to or along adjoining property boundaries such that a roadway connection or street stub shall be provided for development at least every 1,300 feet for each direction (north, south, east, and west) to the maximum extent feasible. The director may waive this requirement where the configuration of existing adjacent development, topography, or the presence of sensitive natural areas makes compliance impractical.

d. ***Vehicular Access to Public Streets***

Unless the decision-making body determines otherwise, and except for in the DT districts, any development of more than 100 residential units or additions to existing developments such that the total number of units exceeds 100 shall be required to provide vehicular access to at least four public streets to the extent reasonably feasible, due to topography, natural features, or the configuration of existing adjacent developments. These connections (if possible) shall be made to foster and accommodate connectivity into, out of, and within the new development, regardless of the macro-level access to and connectivity of the general area.

e. ***Connections to Vacant Land***

Where new development is adjacent to land likely to be developed or redeveloped in the future, all streets, sidewalks, pathways, trails, walkways, and access ways in the development's proposed street system shall continue through to the boundary lines of the site of new development, as determined by the director and the traffic engineer, to provide for the orderly subdivision of such adjacent land or the transportation and access needs of the community.

f. ***Neighborhood Protection from Cut-through Traffic***

Street connections should connect neighborhoods to each other and to local destinations such as schools, parks, greenbelt trail systems, and shopping areas, while (except for in the DT districts) minimizing neighborhood cut-through vehicle traffic movements that are non-local in nature. Outside of the DT districts, configuration of local and internal streets and traffic calming measures should be used to discourage use of the local street system for cut-through collector or arterial vehicle traffic.

g. ***Pedestrian Connectivity***

Where the director and the traffic engineer have determined a vehicular connection required above is not feasible or appropriate, a pedestrian access way shall be provided as long as:

- i. The topography and existing development patterns allow for pedestrian access; and
- ii. The land uses allowed on either end of the potential pedestrian connection are such that may generate pedestrian traffic.

E. Standards for Pedestrian Facilities

1. Purpose

The purpose of this section is to provide convenient, safe, and regular pedestrian facilities along streets and within and between developments. Such facilities create a healthful built environment in which individuals have opportunities to incorporate physical activity, such as walking or bicycling, into their daily routine. Injuries and fatalities are reduced when interactions between pedestrians and vehicles are minimized. Adequate pedestrian facilities meet community goals for mobility and access, as well as for providing transportation choices. Safe pedestrian access for students to their schools is also an essential purpose of these standards.

2. Sidewalks

- a. All sidewalks shall be designed to comply with the standards of the Design Criteria Manual (DCM) and Municipality of Anchorage Standard Specifications (MASS) and shall be improved in accordance with subsection 21.08.050H.
- b. Street improvement projects and new streets in subdivisions in all class A zoning districts except for industrial districts shall install sidewalks on both sides of all streets (local, collector, arterial, public or private, including loop streets). Where indicated in the comprehensive plan, a pathway may replace a sidewalk on one side. Street improvement projects in industrial zoning districts shall install a sidewalk on one side of all local streets, and on both sides of local streets if the new sidewalks would connect to existing sidewalks on both ends and the needed sidewalk length is no greater than one quarter mile.
- c. In cul-de-sacs in class A zoning districts, the following shall apply:
 - i. For cul-de-sacs with fewer than 150 average daily trips and with speeds limited to 25 miles per hour by design, no sidewalks are required on the cul-de-sac stem or bulb.
 - ii. For cul-de-sacs with 150 to 500 average daily trips, and for those with fewer than 150 average daily trips but a design speed of greater than 25 miles per hour, a sidewalk on one side of the cul-de-sac stem is required.
 - iii. For cul-de-sacs with more than 500 average daily trips, or for cul-de-sacs that are used to access a school or a park (notwithstanding subsections c.i. and c.ii. above), sidewalks on both sides of the stem are required.
 - iv. Average daily trips shall be computed by the traffic engineer.
- d. In class B zoning districts, sidewalks, walkways, pathways, and trails shall be provided in accordance with the comprehensive plan. In all cases, pedestrian facilities shall be provided on at least one side of collector and arterial streets.
- e. The requirements of 2.b. and 2.c. shall not apply in steep-slope areas where sidewalks on one side of the street may be approved by the director to reduce excessive slope disturbance, adverse impacts on natural resources, and potential soil erosion and drainage problems.
- f. Development on lots along existing streets in class A zoning districts shall install sidewalks on all lot frontages abutting streets in the following situations:
 - i. In the R-4, R-4A, and commercial zoning districts.
 - ii. In the DT zoning districts as set forth in the provisions of chapter 21.11, *Downtown*.

- iii. Along streets identified in Appendix A of the *Anchorage Pedestrian Plan* as “missing sidewalk” or “inadequate sidewalk”, with a total point rating of five or higher.
- g. Where sidewalks are not specifically called for on both sides of the street by the comprehensive plan, the decision-making body may reduce a requirement to provide sidewalks (or other pedestrian facilities) on both sides of a street after considering the following:
- i. Site conditions and the potential for significant negative impacts on the natural environment;
 - ii. The need to maintain and improve sidewalk continuity;
 - iii. Evidence that a sidewalk would decrease pedestrian safety;
 - iv. Extensive public testimony offering rational arguments against sidewalks;
 - v. Availability of an alternate trail system; and
 - vi. Vehicular speeds and pedestrian safety.
3. **Through-Block Connections**
Within new developments, pedestrian walkways, crosswalks, or multi-purpose trails no less than five feet in width shall be constructed near the center and entirely through any block that is 900 feet or more in length. This standard may be waived during a site plan review, if justified by the decision-making body.
4. **On-Site Pedestrian Walkways**
- a. ***Continuous Pedestrian Access***
Pedestrian walkways are intended to form a convenient on-site circulation system that minimizes conflict between pedestrians and traffic at all points of pedestrian access to on-site parking and building entrances. This subsection E.4. does not apply to single- and two-family development, or to marijuana cultivation facility, marijuana manufacturing facility, industrial, and utility facility uses in the I-1, I-2, MC, and MI zoning districts.
 - b. ***On-Site Pedestrian Connections***
The following walkways shall be provided. Where one walkway fulfills more than one requirement, only one walkway need be provided. If they can provide a relatively direct route, public pedestrian facilities such as public sidewalks shall satisfy any or all of the requirements below.
 - i. A walkway shall connect the primary entrance to the abutting primary street frontage, except where a proposed walkway connection to an alternative street frontage is determined by the director to provide equal or better pedestrian access. No walkway need be provided to the primary street frontage if that frontage is a restricted access street or a frontage road, unless there is a pathway or other pedestrian facility to which access can be provided along the restricted access street or frontage road, in which case a walkway shall connect to that pedestrian facility. The walkway route shall be clear and direct, to the extent reasonably feasible.
 - ii. All primary building entrances on a site shall be connected to the street by a convenient system of walkways. This includes multiple primary entrances into one building, and primary entrances in separate buildings on a site.

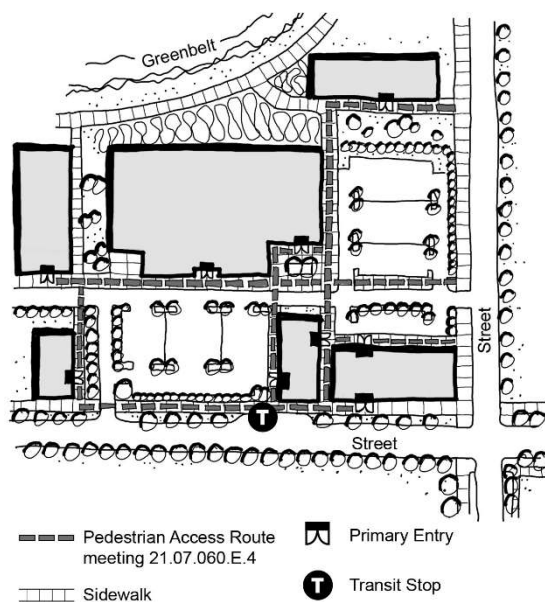

- iii. A walkway shall connect the primary entrances to any transit stop abutting the site, where on an active transit route with scheduled service. The walkway shall be clear and direct to the extent reasonably feasible.
- iv. The primary front entrance of a residential dwelling shall be connected to the street by a walkway as provided in i. through ii. above, or by the dwelling's individual driveway, or by a shared parking courtyard meeting 21.07.060G.23.

c. Walkway Clear Width and Improvements

- i. The minimum width of a required pedestrian walkway shall be five feet of unobstructed clear width, except where otherwise stated in this title. A walkway that provides access to no more than four residential dwelling units may provide an unobstructed clear width of three feet.
- ii. Walkways shall be improved in accordance with subsection 21.08.050H.

d. Walkways and Parking

- i. Where an on-site pedestrian walkway system or required pedestrian area abuts a parking lot or internal street or driveway, the pedestrian facility shall be clearly marked and physically separated from the parking lot or drive, through the use of an upright curb of six inches in height, bollards spaced a maximum of six feet apart, or other physical buffer approved by the traffic engineer; and a change of paving materials distinguished by color, texture, textured edge, or other edge, or striping.
- ii. The vehicle overhang established in table 21.07-9, *Parking Angle, Stall and Aisle Dimensions*, shall not encroach into the minimum required walkway width or area.
- iii. Where an on-site pedestrian walkway crosses an internal street or driveway, the crosswalk shall be clearly marked and delineated through a change in paving materials distinguished by color, texture, textured edge, other edge, or striping, and shall meet the requirements of the Americans with Disabilities Act.

iv. Multifamily or townhouse developments may provide a parking courtyard in lieu of required walkways, where specifically allowed in section 21.07.110 and in conformance with subsection 21.07.060F.23.

e. **Walkways, Landscaping, and Open Space**

Walkways shall be credited toward a required private open space where they are contiguous. A walkway that crosses a required landscaping bed (at or near perpendicular) shall be credited against the required landscaping area and amount of planting material.

5. **Trails**

All trails shall meet the following requirements in addition to the standards contained in the *Areawide Trails Plan, Design Criteria Manual* (DCM), and *Municipality of Anchorage Standard Specifications* (MASS):

- a. All trail connections shall be well-signed with destination and directional signing as approved by the traffic engineer or the parks director as appropriate.
- b. Trails shall be designed in such a manner that motor vehicle crossings can be eliminated or significantly minimized.
- c. Trails that connect to the street system shall do so in a safe and convenient manner as determined by the traffic engineer.

6. **Use and Maintenance of Sidewalks, Walkways, Pathways, and Trails**

a. **Restrictions on Use**

Sidewalks, walkways, pathways, and trails are intended to provide pedestrian access. Vehicle parking, snow storage, garbage containers, merchandise storage or display, utility boxes and poles, signs, trees, and other obstructions shall not encroach into the required minimum clear width of any required sidewalk, walkway, pathway, trail, or other pedestrian way. Pedestrian amenities including bollards are exempt from this requirement.

b. **Maintenance and Snow Removal**

Walkways required by this title shall be maintained in usable condition throughout the year, including snow and ice removal as appropriate. Sidewalks shall be maintained in a usable condition in accordance with AMC title 24.

F. **Pedestrian Frontage Standard**

1. **Purpose**

The pedestrian frontage standard requires site planning and building orientation toward neighborhood streets and sidewalks to facilitate pedestrian access and reduce automobile parking congestion. Objectives include to:

- a. Organize and orient buildings around public streets and associated frontages in a way that frames streets as positive public space, promotes pedestrian activity, and connects to multiple modes of transportation.
- b. Provide clearly defined, safe pedestrian access to building entries that invites people of all abilities and minimizes conflicts with vehicles and parking.
- c. Place active indoor spaces, entrances, and windows on street-facing building facades to improve the visual connection to the street and promote a safe, secure neighborhood.

2. Applicability

Subsection 4. applies to development in areas subject to the urban neighborhood development context standards established in subsection 21.07.010E. effective on November 1, 2025. Subsection 5. applies to development generally until November 1, 2025, and thereafter in the other areas of the municipality. The following are exempt:

- a. Changes of use and other developments that comprise building modification of less than 50 percent of the building replacement value of the building(s) on the site.
- b. Development in Girdwood, Downtown (DT), CE-DO, CE-EVO, PLI, PR, TA, or industrial zoning districts.
- c. Single-family and two-family dwellings constructed prior to January 1, 2016, or on lots of 20,000 square feet or larger, or in Class B zoning districts.
- d. Uses without habitable floor area, such as utility substations.

3. Administrative Adjustments

- a. The Alternative Equivalent Compliance procedure in 21.07.010D. may be used to propose alternative means of complying with the intent of this section.
- b. The director shall approve administrative relief if the applicant demonstrates the adjustment is necessary to compensate for some practical difficulty of the site. This includes reducing the window area requirement by the amount needed to comply with 5-star or affordable housing (21.15.040) energy rating requirements. The department shall keep record of the approved exception with written findings supporting the exception on file.
- c. The director may approve administrative relief for land use permits submitted for review before November 1, 2025 if the applicant demonstrates in writing an undue burden placed upon the affected developments as a result of standards set forth in Table 21.07-3. The department shall keep record of the approved relief with written findings supporting such relief on file. The denial decision shall indicate the most appropriate alternative for the applicant to pursue.

4. Standard for Urban Neighborhood Contexts

The standards of table 21.07-2 apply to the primary frontage and one secondary frontage effective November 1, 2025.

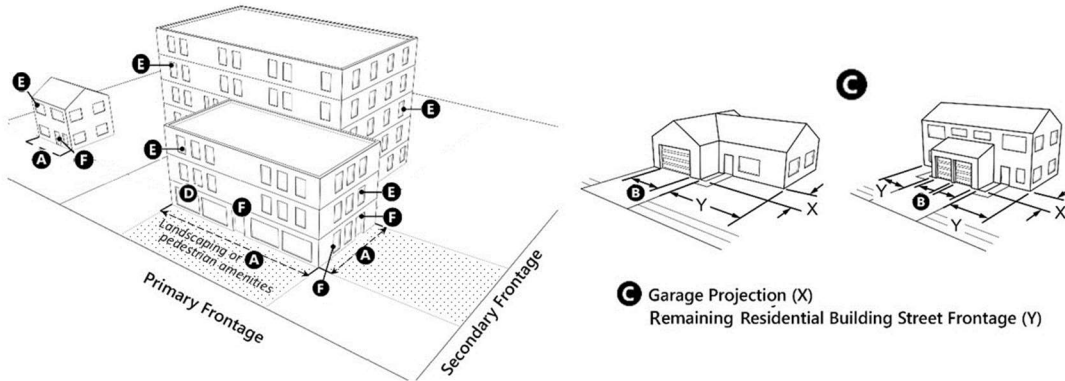

Table 21.07-2: Pedestrian Frontage Standard for Urban Neighborhood Contexts as of November 1, 2025

Site Elements for Pedestrian-Oriented Frontages	Standard
A. Minimum required ground-floor, street-facing building elevation with on-site walkways, pedestrian amenities, or landscaping in front – and no off-street automobile parking or circulation	50% of building elevation width ¹ Lots with alley access: no parking allowed in front of building except in driveways for individual dwellings
B. Maximum allowed width of residential garage entrance(s) on ground-floor street-facing building elevation	40% of building elevation width ¹
C. Maximum allowed distance a garage may project out in front of the rest of the street-facing residential building elevation	No more than 50% of the width of the non-garage portion of the street-facing building
D. Minimum required visual access windows or primary entrances on non-residential ground-floor street-facing building elevation ²	25% of wall area on primary frontage 15% of wall area on second frontage
E. Minimum required windows or primary entrances on residential and upper-floor non-residential street-facing elevations ²	15% of wall area on primary frontage 10% of wall area on second frontage
F. Requirement for primary entrance(s) to be visible from the street via an unobstructed line of sight, and for residential entrances to be covered	Residential: Meet 21.07.060G.16., Covered, Visible Residential Entrance Other uses: at least one entrance
G. Minimum required number of pedestrian amenities from 21.07.060G. (in addition to G.16)	Developments with 10,000 to 20,000 square feet of gross floor area: 1 pedestrian amenity Developments with greater than 20,000 square feet of gross floor area: 2 pedestrian amenities

¹Exception: On lots without alley access residential developments with four dwelling units or less may have a minimum of 20% in A. above and a maximum of 67% in B. above. This footnote exception shall sunset at the close of June 30, 2025.
¹Exception: Shared parking courtyards that comply with subsection 21.07.060G.22. are exempt from A. above.
²Visual access windows shall have a sill height of no more than four feet above finished grade. Rules for measuring window area as a percentage of building wall area are provided in 21.15.0200. Visual access windows ("Window, providing visual access"), primary entrance, and ground-floor wall area are defined in 21.15.040.

5. General Standard for Development

The standards of Table 21.07-3 apply to the primary frontage and one secondary frontage.

Table 21.07-3: General Pedestrian Frontage Standard for Development	
Required Site Elements for Pedestrian-Oriented Frontages	Standard
A. Minimum required ground-floor, street-facing building elevation with on-site walkways, pedestrian amenities, or landscaping in front – and no off-street automobile parking or circulation ¹	20% of building elevation width, on one frontage
B. Maximum allowed width of residential garage entrance(s) on ground-floor street-facing building elevation	67% of building elevation width
C. Maximum allowed distance a garage may project out in front of the rest of the street-facing residential building elevation	No more than the width of the non-garage portion of the street-facing building elevation
D. Minimum required visual access windows or primary entrances on non-residential ground-floor street-facing building elevation ^{1,2}	15% on primary frontage 10% on secondary frontage
E. Minimum required windows or primary entrances on residential and upper-floor non-residential street-facing elevations ^{1,2}	10% on primary frontage 5% on secondary frontage
F. Requirement for primary entrance(s) to be visible from a street via an unobstructed line of sight and for residential entrances to be covered ¹	Residential: Meet 21.07.060G.16., Covered, Visible Residential Entrance Other uses: at least one entrance
G. Minimum required number of pedestrian amenities from 21.07.060G. (in addition to G.16)	Developments with greater than 20,000 square feet of gross floor area: 1 pedestrian amenity

¹Exception: Shared parking courtyards that comply with subsection 21.07.060G.22. are exempt from A., D., E., and F. above. Non-residential buildings located more than 100 feet from the applicable street rights-of-way are exempt from A., D., E., and F. above.
²Visual access windows shall have a sill height of no more than four feet above finished grade. Rules for measuring window area as a percentage of building wall area are provided in 21.15.0200. Visual access windows ("Window, providing visual access"), primary entrance, and ground-floor wall area are defined in 21.15.040.

G. Pedestrian Amenities Menu

1. Purpose

This section defines and provides standards for pedestrian amenities that are used in developments to satisfy a requirement, menu choice, or incentive in this title. The standards in this section give predictability for applicants and the public for the minimum acceptable standards for pedestrian amenities. It encourages amenities that will improve and enhance the community and respond to Anchorage’s northern latitude climate.

2. Applicability

Pedestrian amenities shall meet the minimum standards of this section to be credited toward a requirement, menu choice, or incentive of this title, except where specifically provided otherwise in this title. The standards of this section do not apply to amenities that are not counted toward a requirement, menu choice, or incentive under this title.

3. Administrative Adjustments

The alternative equivalent compliance procedure set forth in subsection 21.07.010D. may be used to propose alternative means of complying with the standards of this subsection 21.07.060G.

4. Enhanced On-site Walkway

An enhanced on-site walkway is intended to provide an option for applicants to receive credit for exceeding the minimum development standards for walkways and improving pedestrian convenience, comfort, and safety on the site. Enhanced on-site walkways provide additional width for pedestrian movement and peripheral space that accommodates landscaping, furniture, and utilities.

- a. An enhanced on-site walkway shall have a pedestrian movement zone with a continuous, unobstructed walkway clear width of at least eight feet, or six feet where providing access only to four or fewer residential dwelling units. Where adjacent to a ground-floor building elevation it shall also have a building interface zone a minimum of two feet in width for building foundation landscaping or space for opening doors or seating and transition pedestrian spaces. In addition to the pedestrian movement zone and any building interface zone, the enhanced on-site walkway shall have a buffer space of at least two feet in width where abutting motor vehicle parking lots, circulation aisles, or driveways. The buffer spaces shall accommodate landscaping beds, fencing or bollards, light poles, utilities, benches, and other furnishings.
- b. A minimum of two pedestrian features as defined by this title (21.15.040) shall be provided along the enhanced walkway, with at least one for every 50 feet of the walkway length.
- c. Enhanced on-site walkways shall provide continuous direct connections from building primary entrance(s) to surrounding public streets and sidewalks and be publicly accessible or available to all residents of the development.

5. Ice-Free (Snow Melting) Walkway

An ice-free (snow melting) walkway has a heated surface for the full extent of the walkway clear width. The walkway shall be maintained as ice-free at all times in areas required to be publicly accessible, and otherwise during all hours of operation of an establishment.

6. Plaza or Courtyard

A plaza is an open space which is designed to be used for relaxation, conversation, eating, or other outdoor activities.

- a. A plaza shall contain at least one pedestrian feature as defined by this title for each 200 square feet of plaza or courtyard area.
- b. A plaza shall be visible and directly accessible from the public sidewalk and at no point be more than five feet above nor more than 12 feet below the curb level of the nearest street.
- c. A plaza shall be unobstructed to the sky except for certain permitted obstructions such as canopies or awnings, landscaping, or ornamental features such as fountains and flag poles.
- d. A plaza shall be positioned so that at least two-thirds of its area receives access to at least four hours of direct or reflected sunlight on March 21 and September 21. A plaza or courtyard may be credited towards a requirement, menu choice, or bonus as long as it meets this standard. The director may reduce this requirement in cases where topography or vegetation shadow the site. Reductions shall be the minimal action that would address these factors.

- e. Plazas shall not be paved with asphalt.

7. Housing Courtyard

A housing courtyard may be created when a multifamily building or buildings are arranged or configured to enclose and frame a common private open space. To receive credit as a housing courtyard, the space shall achieve the following:

- a. The residential building(s) shall enclose a clearly defined courtyard open space. The structure(s) surrounding the housing courtyard may, for example, form an O, L, or U shaped enclosure.
- b. A courtyard shall comply with the plaza requirement for pedestrian features, and with the common private open space standards of section 21.07.030.
- c. All individual dwelling units around the perimeter of a courtyard shall have windows, entrances, and/or transitional spaces such as porches or balconies that face the courtyard.
- d. A courtyard shall have a solar orientation as defined by this title in terms of openings in the courtyard and the lower height of surrounding buildings.

8. Transit Stop or Transit Shelter

A transit stop or transit shelter shall meet or exceed the minimum design standards established by the transit facilities design guidelines in the *Design Criteria Manual*.

9. Pedestrian Shelter such as a Canopy, Awning, or Marquee

A pedestrian shelter is a roof-like structure extending out from the building face that provides year round overhead protection from precipitation and wind, and that can provide visual interest and wayfinding orientation to primary entrances, passenger loading areas, or waiting areas. Pedestrian shelter may be composed of awnings, canopies, marquees, cantilevered overhangs, colonnades, or similar overhangs along the pedestrian route.

- a. A pedestrian shelter shall have a minimum dimension of six feet measured horizontally from the building wall, or shall extend to a line two feet from the curb line of the street or nearest motor vehicle area, whichever is less.
- b. A pedestrian shelter shall have a minimum vertical clearance of eight feet and a maximum vertical clearance of 12 feet, except that a pedestrian shelter that projects out more than eight feet measured horizontally from the building wall shall have a maximum vertical clearance of 16 feet.
- c. A pedestrian shelter may be indented as necessary to accommodate street trees, landscaping beds, street lights, bay windows, or similar building accessories. A pedestrian shelter shall not extend out to within three feet of the center of the main trunk of a street tree.
- d. A pedestrian shelter shall incorporate architectural design features of the building from which it is supported.

10. Arcade (or Building Recess)

An arcade is a covered passageway created by the overhanging upper portion of the building along a sidewalk or walkway to provide a sheltered area at grade level. An arcade is usually separated from the adjacent street, sidewalk/walkway, or pedestrian space by a line of supporting columns or arches. A ground level building recess without supporting columns may also receive credit if it achieves the following standards:

- a. An arcade shall be developed as a continuous covered space extending along a street, plaza, or courtyard or other pedestrian open space. An arcade shall be

open for its entire length to the street or pedestrian open space, except for building columns.

- b. An arcade shall have a minimum vertical clearance of no less than 12 feet, and on average no greater than 18 feet.
- c. An arcade shall have a minimum horizontal walkway clear width of eight feet between the building and any supporting columns, and a maximum covered width of 20 feet.
- d. An arcade shall not at any point be above the level of the adjacent sidewalk, walkway, or pedestrian open space (whichever is higher). The width and spacing of the supporting columns shall be such that maximum visibility is maintained.
- e. The spacing and rhythm of the supporting columns shall relate to the structural or architectural pattern of the building and shall be consistent along the length of the arcade.
- f. No off-street parking spaces, passenger loading zones, driveways, or off-street loading berths are permitted anywhere within an arcade or within 10 feet of any portion thereof, unless the decision-making body determines that such activity will not adversely affect the air quality or functioning of the arcade. In no event shall such vehicular areas be eligible for credit as part of the arcade.
- g. An arcade shall be publicly accessible at all times.

11. Atrium, Galleria, or Winter Garden

An atrium, galleria, or winter garden is a publicly accessible sunlit interior space suited for year-round public use, and which takes advantage of windows and sunlight access to provide brightness, orientation, and visual connections to the outdoors.

- a. An atrium, galleria, or winter garden shall be developed and maintained as a temperature controlled, publicly accessible space furnished with features and amenities that encourage its use.
- b. An atrium, galleria, or winter garden shall contain at least one pedestrian feature as defined by this title for each 200 square feet of floor area.
- c. An atrium, galleria, or winter garden shall be co-located with primary entrances and pedestrian activity areas, and either adjoin or directly connect to a publicly accessible sidewalk or open space.
- d. The publicly accessible portion of the atrium, galleria, or winter garden shall be at least 400 square feet, with a minimum dimension of 16 feet.
- e. At least half of an atrium, galleria, or winter garden's ceiling area and at least a portion of its wall area shall consist of transparent glazing.
- f. An atrium, galleria, or winter garden shall have access to direct and/or reflected sunlight for at least four hours daily for eight months of the year.

12. Sun Pocket (or Sun Trap)

A sun pocket or sun trap is a pedestrian space that captures direct and reflected sunlight. A sun pocket shall be a clearly defined open space partly sheltered by building walls, fences, or landscape features, such as a C, L, or U shaped semi-enclosure. The protected space shall contain at least 250 square feet of pedestrian area that is exposed to direct and reflected sunlight access for at least six hours on March 21 and September 21.

13. Reflected Sunlight

Reflected sunlight as a pedestrian amenity is created by a light-colored, partially reflective, upper-story façade surface that redirects sunlight radiation to pedestrian spaces and walkways to brighten or increase the comfort level in those spaces.

- a. The reflective façade surface shall have a solar orientation.
- b. The reflective façade surface shall have a reflectance of at least 50 percent and no greater than 75 percent in order to avoid excessive glare.
- c. The reflective façade surface shall be an upper floor above ground-level.
- d. Reflected sunlight shall fall on at least 400 square feet of a publicly accessible walkway, open space, and/or abutting ground-level wall area for at least four hours on March 21 and September 21.

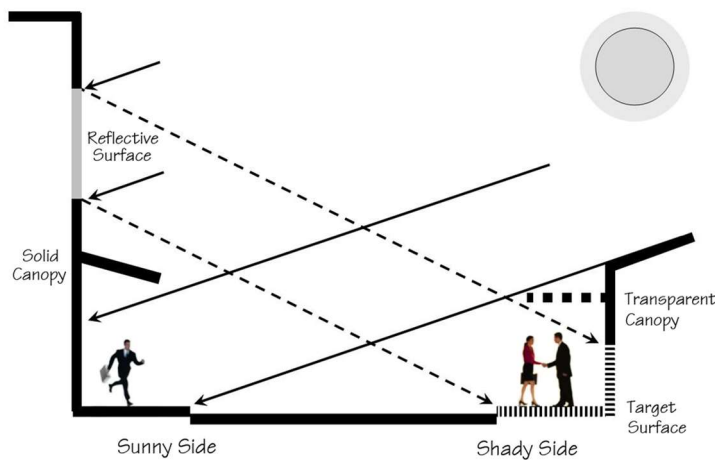

14. Sheltered Transition Space

A sheltered transition space is an outdoor or glass covered space such as café seating along a building façade that provides a comfortable transition between indoor areas and unsheltered outdoor spaces.

- a. A sheltered transition space shall be a minimum of 400 square feet.
- b. A sheltered transition space shall comply with the dimensional standards for pedestrian shelter or arcade.
- c. A sheltered transition space shall contain a minimum of one pedestrian feature as defined by this title.
- d. A sheltered transition space shall not obstruct the minimum clear width of the adjoining walkway or sidewalk.

15. Separated Walkway to the Street

The development shall connect the building primary entrances to the street with a clear and direct walkway that is not routed through a parking facility or across vehicle driveways or circulation aisles. The minimum clear width portion of the walkway shall be separated from the parking facility by at least five feet.

16. Covered, Visible Residential Entrance

A porch, stoop, or landing sheltered by a roof is intended to give visual emphasis to the building entrance as an aid in wayfinding, and help provide safe, convenient access to residential buildings from the street. Residential primary entrances shall meet the following standards:

- a. The entrance shall incorporate a porch, stoop, or landing with an internal dimension of at least 16 square feet, and a permanent, sheltering roof covering at least 12 square feet.
- b. The porch, stoop, or landing shall be distinguished from adjoining areas and vehicle parking by vertical separation or a change in surfacing material.
- c. At least one primary entrance, and at least half of individual dwelling unit primary entrances in a multi-unit development, shall be visible (via an unobstructed line of sight) from a street or a common private open space (21.07.030), a plaza or courtyard (21.07.060G.6.), a housing courtyard (21.07.060G.7.), or a shared parking courtyard (21.07.060G.23.).

17. Enhanced Primary Entrance

An enhanced building entry is intended to provide a more prominent and inviting primary pedestrian entrance. To receive credit, the enhanced primary entrance shall incorporate at least three of the following features:

- a. Outdoor sheltering roof feature projecting from the building façade such as an overhang, portico, canopy, marquee with an inside dimension of at least 16 square feet;
- b. Recessed and/or projected entrance or other building wall modulation with projections or recesses in the building wall plane;
- c. Changes in the building's main roofline such as arches, peaked roof forms, or terracing parapets;
- d. Changes in siding material or exterior finishes, or façade detail features such as tilework that emphasize the entrance;
- e. Entrance plaza, patio, or similar common private open space;
- f. Landscaping not otherwise required by this title, such as integrated planters, landscape accent lighting or special paving treatments; or
- g. One or more pedestrian features (21.15.040) such as pedestrian-scale lighting or seating.

18. Enhanced Façade Transparency

Increase the windows and/or primary entrances on street-facing building elevations which are subject to the window requirement in 21.07.060F., by an additional five (5) percent of the wall area.

19. Pedestrian Frontage Free of Parking in Front

In urban neighborhood development contexts (21.07.010E.), provide a street frontage without driveways, parking, or loading facilities in front of at least 75% of the ground-floor, street-facing building elevation. In other areas, provide such a frontage in front of at least 33% of the street-facing building elevation.

20. Site Entry Feature

Highlight and define a pedestrian entrance to a development site using three or more of the following elements:

- a. Landscape treatment with seasonal color and trees, which clearly distinguishes and highlights the site entry.
- b. Plaza or courtyard as described in subsection 21.07.060G.6.
- c. Identifying building primary entrance form including a covered entry, when the primary entrance is within 50 feet of the site entrance.
- d. Special paving, pedestrian walkway area lighting, ornamental lighting, and/or bollards.
- e. Ornamental gate and/or fence.

21. Pedestrian-Interactive Building

A pedestrian-interactive building is intended to provide interior spaces that engage the sidewalk with street-facing windows and entrances, and activities and services that support neighborhood residents, and generally contribute to the activity level and quality of the pedestrian environment of the neighborhood or district.

- a. A pedestrian-interactive building shall provide a primary entrance facing the street. Entrances at building corners facing a street may be used to satisfy this requirement.
- b. A pedestrian-interactive building shall contain habitable floor area at least 24 feet deep extending along a minimum of 50 percent of the length of the ground-floor, street-facing building elevation in Urban Neighborhood Development Contexts, (21.07.010E.), and 30 percent elsewhere. The habitable floor area may include pedestrian entrances, entry lobbies or atriums, and stairwells.
- c. At least 50 percent of the street-facing building elevation width of a pedestrian-interactive building shall have no parking facilities in front.
- d. Street-facing wall areas of a non-residential use shall be 50 percent visual access windows or primary entrances on the ground floor, and 20 percent windows above the ground floor.,
- e. Street-facing wall areas for residential uses shall be at least 20 percent windows or primary entrances.
- f. Where a building has three or more street frontages, these criteria apply along only two of the frontages.

22. Enhanced Street Sidewalk

An enhanced street sidewalk is intended to provide an option for applicants to receive credit for exceeding the minimum development standards for sidewalks. An enhanced street sidewalk promotes sidewalk widening and streetscape enhancements to support higher levels of pedestrian activity, comfort, and safety in the district. An enhanced street sidewalk with “complete street” (21.15.040) style amenities may be provided in lieu of required site perimeter landscaping as determined through an administrative site plan review, and subject to the following:

- a. The enhanced street sidewalk cross-section shall be at least 12 feet wide, and include a pedestrian movement zone, building interface zone, and street interface zone (21.15.040). The pedestrian movement zone shall have a clear width of at least six feet. The street interface zone shall be at least two feet wide from back of curb, and four feet wide along major arterials. Where a building adjoins the sidewalk, there shall be a building interface zone at least two feet wide.

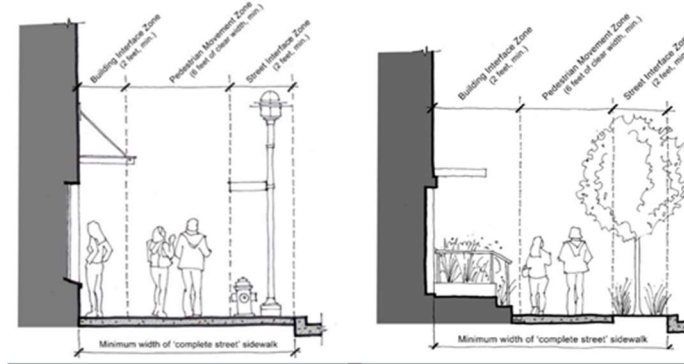

Enhanced Street Sidewalks in Commercial and Residential Settings

- b. The enhanced street sidewalk shall provide at least half the number of trees and shrubs that would otherwise have been required for site perimeter landscaping. Shrubs are not required if perennials are substituted for shrubs on a three to one basis or if the tree planting bed is provided as a suspended pavement system with a minimum of 300 cubic yards of soil per tree.
- c. The enhanced street sidewalk may be placed wholly or in part within a right-of-way, subject to approval of the traffic engineer and municipal engineer.
- i. The enhanced street sidewalk shall be subject to the applicable requirements of title 24, including sections 24.30.020., *Permit to use Public Places*, and 24.90, *Encroachment Permit*.
 - ii. Existing improvements that meet the standards of the enhanced street sidewalk may be counted towards the requirements of this section, subject to approval by the director.
 - iii. The owner shall maintain landscaping and amenities for the enhanced street sidewalk within the right-of-way.
 - iv. Where the right-of-way is not adequate or cannot be configured to accommodate the enhanced street sidewalk, then the development shall be set back from the street frontage as necessary to accommodate part of the improvements within the property. A public use easement shall be recorded for any part of the designated sidewalk width to be located within the subject parcel.

23. Shared Parking Courtyard

A parking courtyard is a pedestrian-oriented parking facility for residential developments that uses the principles of a “Woonerf Street” or “Play Street.” It is designed and operated as a shared space to allow all resident users, not only drivers, to use it safely. A parking courtyard that is credited towards a residential pedestrian facility requirement or menu choice of this title shall meet the following standards:

- a. An administrative site plan review is performed, unless a higher level of review is already required;

- b. The parking courtyard serves no more than eight dwelling units and contains no more than 12 parking spaces (not including garage spaces in individual dwellings);
- c. The parking courtyard is a dead end and does not lead or provide access to other dwelling units, parking facilities, or streets;
- d. A walkway is provided between the parking courtyard and the street—the common access driveway does not qualify as a pedestrian walkway;
- e. A special paving scheme and landscape treatment is applied, as approved through the review;
- f. The space is designed for both vehicles and people, with an emphasis on pedestrians and usable, safe, and attractive pedestrian and play space, as approved through the review; and
- g. The parking courtyard achieves the intent of this title for pedestrian access, as determined through the review.

(AO 2012-124(S), 2-26-13; AO 2013-117, 12-3-13; AO 2015-82, 7-28-15; AO 2015-100, 10-13-15; AO 2017-55, 4-11-17; AO 2020-38, 4-28-20; AO 2022-80(S), 11-22-2022; AO 2023-50, 7-11-23; AO 2024-24, 4-23-24)

21.07.070 NEIGHBORHOOD PROTECTION STANDARDS

A. Purpose and Relationship to Other Requirements

This section makes available a menu of additional tools to use in discretionary approvals to protect residential neighborhoods from potential adverse impacts of adjacent nonresidential uses, including limitations on hours of operation, noise, and lighting.

B. Discretionary Conditions

A decision-making body through application of this section shall:

1. Make findings regarding the potential adverse impact that is anticipated by the proposed development;
2. Propose conditions that are specifically related and commensurate to the anticipated impacts identified in the findings; and
3. Propose conditions that are the minimum necessary to avoid or mitigate the anticipated impacts identified in the findings.

C. Nonresidential Development Adjacent to Existing Residential Use

As a condition of the approval of any conditional use permit, site plan review, subdivision, or variance of any nonresidential use located within 200 feet of any residential district, the decision-making body shall be authorized to impose conditions that are necessary to reduce or minimize any potential adverse impacts on residential property. Such conditions shall be based on findings which support the imposed condition as required by subsection 21.07.070B., and may include but are not limited to the following:

1. Hours of operation and deliveries;
2. Location on a site of activities that generate potential adverse impacts on adjacent uses, such as noise and glare;
3. Placement of trash receptacles, compactors, or recycling;

4. Location and screening of loading and delivery areas, garages, vehicle fleet parking, or vehicle maintenance areas;
5. Lighting location, intensity, and hours of illumination;
6. Placement and illumination of outdoor vending machines, telephones, or similar outdoor services and activities;
7. Additional landscaping and screening to mitigate adverse impacts;
8. Height restrictions to preserve light and privacy;
9. Ventilation and control of odors and fumes;
10. Paving to control dust; and
11. Location and orientation of changeable type or illuminated signs, to protect residential character and privacy and views from residential units.

D. Residential Development Adjacent To Existing Nonresidential Use

When a residential development is proposed adjacent to an existing commercial, commercial marijuana, or industrial use, the decision-making body may impose neighborhood protection standards, including but not limited to increased landscaping, traffic calming measures, and requiring the residential development to be configured and dwelling units located to minimize potential conflicts with or adverse impacts from the existing nonresidential development. Any required mitigation measures shall be installed and maintained by the residential development, not the existing commercial, commercial marijuana or industrial use.

(AO 2012-124(S), 2-26-13; AO 2017-55, 4-11-17)

21.07.080 LANDSCAPING, SCREENING, AND FENCES

A. Purpose

This section is intended to ensure that new landscaping and the retention of existing vegetation is an integral part of all development. It is also the intent of this section to provide flexible requirements that encourage and allow for creativity in landscape design. More specifically, these provisions are intended to:

1. Visually enhance industrial, commercial, commercial marijuana, community use, and residential development through retention of existing native or ornamental vegetation or through new landscaping improvements.
2. Integrate new or renovated development into the surrounding context of the community including its neighborhoods and street corridors.
3. Separate, screen, and buffer adjacent incompatible land uses through the use of landscape plantings, fencing, and other appropriate landscape architectural features.
4. Reduce and treat runoff of storm water to preserve the quality of local streams and water bodies.
5. Promote the use of existing vegetation and retention of trees, woodlands, habitat, and urban forest.
6. Reduce runoff and erosion, control dust, and preserve air and water quality.

7. Encourage use of native plants or provide landscaping that is compatible with the climate and natural setting of the municipality and can provide desired effects even during harsh urban and winter conditions.

B. Exemption for Temporary Uses

Unless required under section 21.05.080, temporary uses in accordance with section 21.05.080 are exempt from the requirements of this section.

C. Landscape Plan

1. All landscaping and screening required under this section 21.07.080 shall be reflected on a landscape plan for review and approval by the decision-making body.
2. Minimum requirements for the landscape plan are as follows:
 - a. Where the sum of the required perimeter and parking lot landscaping is less than 1,000 square feet, an indication on the plan showing where the landscaping will be and the code requirements for landscaping.
 - b. Where the sum of the required perimeter and parking lot landscaping is greater than 1,000 square feet, the landscape plan must be prepared by a licensed landscape architect registered by the State of Alaska consistent with AS 08.48 and 12 AAC 36. Additional requirements are as follows:
 - i. Plan scale shall be easily readable and not smaller than one inch equals 30 feet.
 - ii. Plans and/or schedules shall call out the common and scientific name for each plant type or ground cover to be used.
 - iii. The plan shall identify plant locations and sizes in accordance with the sizing standards of the American Standard for Nursery Stock (ANSI Z60.1-2004) as published by the American Nursery and Landscape Association.
 - iv. The plan shall identify locations and areas where existing native vegetation is being used to fulfill the requirements of this section.
 - v. The location of buildings, walkways, vehicular circulation (to include adjacent streets), retaining walls, and fences shall be indicated.
 - vi. Topography, expressed in contours or spot elevations, shall be identified on plans. Additionally, all drainage features to include swales, biofiltration swales, drainage basins, snow storage and disposal areas, and any inlets for storm drains shall be identified on plans. A separate plan, detailing site grading, that includes contours and/or spot elevations is acceptable.
 - vii. The plan shall identify existing and proposed utility elements such as easements, transformers, utility poles, overhead and underground utility lines, street lights, and curb cuts that affect the landscape plan.
 - viii. Planting details shall be provided.
 - ix. North arrow and scale shall be included.

D. Cross-References to Other Requirements

1. Landscaping

Any use that is required to provide landscaping or screening pursuant to the district-specific standards of chapters 21.04, 21.09, and, 21.10; the use-specific standards of chapters

21.05, 21.09, and 21.10; or any applicable standards of other sections of this chapter 21.07, chapter 21.09, or chapter 21.10; shall provide such landscaping or screening. In the event of a conflict between other requirements and the requirements of this section 21.07.080, the more restrictive provisions shall govern.

2. Walkways

Refer to subsection 21.07.060E.4.e.

3. Parking and Loading Facilities and Vehicular Overhangs

Refer to subsections 21.07.090H.3. and H.12.

4. Private Open Space

Refer to subsection 21.07.030D.

5. Snow Storage

Refer to subsection 21.07.040F.

E. Types of Landscaping

Four types of landscaping may be required for a development, depending on the use and zoning district of the property and adjacent properties, and the portion of the property involved. These types of landscaping are: (1) site perimeter landscaping; (2) parking lot landscaping—perimeter and interior; (3) site enhancement landscaping applied in site interiors; and (4) tree requirements for new residential development. Minimum requirements for these landscaping types are set forth in subsections 21.07.080E.1. through E.4. below and in table 21.07-4: *Landscaping Specifications*.

TABLE 21.07-4: LANDSCAPING SPECIFICATIONS			
TYPE OF LANDSCAPING	BED WIDTH OR AREA/LOCATION REQUIRED	PLANT MATERIALS REQUIRED	OPTIONAL DESIGN STANDARDS
SITE PERIMETER LANDSCAPING REQUIREMENTS			
Visual Enhancement Landscaping (L1)	<p>Minimum average planting bed width: 8 feet as measured for each leg of the perimeter.</p> <p>Minimum planting bed width: 5 feet.</p> <p>No more than one-half the property line length or 50 feet, whichever is less, may have a planting bed width less than 8 feet in width. The maximum bed width used for the calculation of average bed width may not be greater than 12 feet.</p>	<p>Provide 1 tree and 6 shrubs per 20 linear feet of property line requiring visual enhancement landscaping.</p> <p>All areas within the planting bed shall be covered with living ground cover, turf, or mulch.</p> <p>All trees, shrubs, and ground covers shall be chosen for suitable hardiness and length of season for the specific area to be planted.</p>	<p>Use of raised planters, pedestrian amenities, and pedestrian scale lighting may be used to offset up to 1/3 of trees and 1/3 of shrubs, through an administrative site plan review.</p> <p>Up to 1/2 of total required shrubs may be substituted with perennial plantings at a ratio of three 1-gallon container perennials for every shrub required.</p> <p>Trees may be substituted with an equal number of shrubs at 6-foot minimum planting height in utility easements with overhead lines.</p>
Buffer Landscaping (L2)	<p>Minimum average planting bed width shall be 15 feet, with minimum width at any point not less than 10 feet, except as modified by the Optional Design Standards, in which case the overall minimum planting bed width shall be 10 feet.</p>	<p>Provide 2 trees and 6 shrubs per 20 linear feet of property line requiring buffer landscaping.</p> <p>At minimum, 1/2 of all trees shall be coniferous.</p> <p>Distribute trees and shrubs evenly along the length of the planting bed.</p> <p>All areas within the planting bed shall be covered with living ground cover, turf, or mulch.</p> <p>If relying on existing vegetation to meet these requirements, use of a site-obscuring or screening fence as an optional design standard is not allowed.</p> <p>All trees, shrubs, and ground covers shall be chosen for suitable hardiness and length of season for the specific area to be planted.</p>	<p>A 6-foot high ornamental sight-obscuring or screening fence may be used in lieu of 5 feet of planting bed width on side or rear property lines, but not along streets or street rights-of-way. The fence shall be situated within or on the edge of the planting bed, except where utilities or existing conditions create a conflict.</p> <p>Trees may be substituted with an equal number of shrubs at 6 feet minimum planting height in utility easements with overhead lines.</p>
Screening Landscaping (L3)	<p>Minimum planting bed width of 30 feet, except as allowed by the Optional Design Standards.</p>	<p>Provide 3 trees and 10 shrubs per 20 linear feet of property line requiring screening landscaping.</p> <p>At minimum, 75% of all trees shall be coniferous.</p> <p>Trees and shrubs shall be evenly distributed along the frontage.</p> <p>All areas within the planting bed shall be covered with living ground cover, turf, or mulch.</p> <p>All trees, shrubs, and ground covers shall be chosen for suitable hardiness and length of season for the specific area to be planted.</p>	<p>On side or rear property lines, but not along streets or street rights-of-way, planting bed width may be reduced by 10 feet with provision of an eight-foot high ornamental screening fence.</p>

TABLE 21.07-4: LANDSCAPING SPECIFICATIONS			
TYPE OF LANDSCAPING	BED WIDTH OR AREA/LOCATION REQUIRED	PLANT MATERIALS REQUIRED	OPTIONAL DESIGN STANDARDS
Freeway Landscaping (L4)	<p>Freeway landscaping requirements shall apply to any lot abutting the right-of-way of:</p> <ol style="list-style-type: none"> 1. Seward Highway between Tudor Road and Potter Valley Road. 2. Glenn Highway between Boniface Parkway and the northern municipal boundary. 3. Minnesota Drive/O'Malley Road between International Airport Road and the Old Seward Highway. <p>Minimum planting bed width of 30 feet, except as allowed by the Optional Design Standards.</p>	<p>Provide 3 trees and 10 shrubs per 20 linear feet of property line requiring freeway landscaping.</p> <p>At minimum, 1/2 of all trees shall be coniferous.</p> <p>Trees and shrubs may be distributed along frontage at owner's discretion.</p> <p>All areas within the planting bed shall be covered with living ground cover, turf, or mulch.</p> <p>All trees, shrubs, and ground covers shall be chosen for suitable hardiness and length of season for the specific area to be planted.</p>	<p>Planting bed width may be reduced by 10 feet with provision of an 8-foot high ornamental screening fence. If this option is chosen, the fence shall be set back 20 feet from the right-of-way, plant material requirements remain the same, and all required plantings shall be on the freeway side of the fence.</p>
PARKING LOT LANDSCAPING REQUIREMENTS			
Parking Lot Perimeter Landscaping	<p>Same as perimeter landscaping bed width requirements for L1 or L2 landscaping, as applicable. Refer to L1 and L2 perimeter landscaping requirements above in this table.</p>	<p>As required for L1 visual enhancement or L2 buffer landscaping (see subsection E.2.b.ii.)</p> <p>When not serving as required site perimeter landscaping, trees and shrubs may be grouped to best serve the design intentions for the site and promote safe use. Sight-lines for entry and egress shall be considered for placement of landscaping.</p>	<p>Where L1 visual enhancement landscaping is required in the same location as site perimeter landscaping, the requirement for parking lot landscaping takes precedence—no use of optional design standards allowed.</p> <p>Where parking lot perimeter landscaping is in the same location as a higher level of site perimeter landscaping, the site perimeter landscaping requirement takes precedence.</p>
Parking Lot Interior Landscaping	<p>Provide total area in accordance with parking lot interior landscaping requirements in subsection E.2.c.</p> <p>Minimum area for individual beds shall be 165 square feet.</p> <p>Minimum bed width: 8 feet.</p>	<p>1 tree and 6 shrubs per 150 square feet of total internal landscaping required.</p> <p>All areas within the planting bed shall be covered with living ground cover, turf, or mulch.</p> <p>Plant materials shall be evenly distributed throughout planting beds in the parking lot.</p>	<p>Individual planting beds that are designed to be used for biofiltration may substitute up to 3/4 of the required trees and 2/3 of the required shrubs with site appropriate herbaceous plant material in planting beds designed as rain gardens according to the municipal Low Impact Development Design Guidance Manual (latest edition), at a ratio of 12 plants per tree and 2 plants per shrub.</p>
SITE ENHANCEMENT LANDSCAPING REQUIREMENTS			
Site Enhancement Landscaping	<p>Provide on all areas of the site not occupied by buildings, structures, driveways, walkways, off-street parking, or other authorized uses or installations, and not otherwise devoted to landscaping required by this title.</p>	<p>Areas subject to site enhancement landscaping shall be covered with living ground cover, turf, or planting beds with trees and shrubs, at the discretion of the property owner.</p> <p>Existing natural vegetation can be applied toward meeting site enhancement landscaping requirements.</p>	

1. Site Perimeter Landscaping Requirements

a. Purpose

Site perimeter landscaping separates land uses of different characteristics or intensities, to minimize the effects of one land use on another. Perimeter landscaping also marks the interface between public streets and individual property. Four basic levels of site perimeter landscaping are provided to accommodate a variety of land uses at a variety of intensities: (1) visual enhancement landscaping; (2) buffer landscaping; (3) screening landscaping; (4) freeway landscaping. Specifications for these landscaping types are found in table 21.07-4: *Landscaping Specifications*.

b. Applicability

Site perimeter landscaping shall be provided along the perimeter property line of development sites in accordance with table 21.07-5: Minimum Site Perimeter Landscaping, except for the following:

- i. At approved points of pedestrian or vehicle access;
- ii. On individual single-family and two-family lots that are not being developed as part of a subdivision, unless required elsewhere in this title; and
- iii. Along alleys.

c. Exceptions

- i. Development which is eligible to use enhanced street sidewalk environment standards of subsection 21.07.060G.22. may use those standards that modify the requirements of required visual enhancement or buffer landscaping along public streets.
- ii. L4 freeway landscaping may be replaced with L2 buffer landscaping in the following situations:
 - (A) Any lot whose area, less the 30-foot setback area for the L4 freeway landscaping, is less than the minimum lot area required in the zoning district; or
 - (B) Any lot whose depth, excluding all setbacks required by this title, is less than 100 feet.

TABLE 21.07-5: MINIMUM SITE PERIMETER LANDSCAPING – BY ABUTTING DISTRICT OR STREET

Abutting District or Street	Required Level of Site Perimeter Landscaping (Levels 1-4) ^{1, 2, 3}													
	R-6, R-8, R-9, R-10, TA	R-1, R-1A, R-2A, R-2D, R-5, R-7	R-2M	R-3, R-3A	R-4, R-4A	PLI	B-1A, B-1B, B-3, RO	I-1, I-2, MC, MI	PR	Freeway	Arterial, Expressway	Collector	Local Street	
R-6, R-8, R-9, R-10, TA		L2	L2	L2	L2	L2	L2	L2		L4	L2			
R-1, R-1A, R-2A, R-2D, R-5, R-7	L2		L2	L2	L2	L2	L2	L2		L4	L2	L1		
R-2M	L2	L2			L2	L2	L2	L2		L4	L2	L1		
R-3, R-3A	L2	L2				L2	L2	L2		L4	L2	L1	L1	
R-4, R-4A	L2	L2	L2			L2	L1	L2		L4	L1	L1	L1	
PLI	L2	L2	L2	L2	L2		L1	L1	L1	L4	L1	L1	L1	
B-1A, B-1B, B-3, RO	L2	L2	L2	L1	L1	L1		L1	L2	L4	L1	L1	L1	
I-1, I-2, MC, MI, AF	L2	L2	L2	L2	L2	L1	L1		L2	L4	L1	L1	L1	
PR						L1	L2	L2		L4	L1	L1	L1	

NOTES:

¹ This table lists minimum site perimeter landscaping standards. Other chapters or sections of title 21 may have stricter site perimeter landscaping standards which would be used instead of the standards listed in this table.

² L3 screening landscaping is not included in this table as it only occurs as a use-specific standard for certain industrial uses, or through development-specific application in processes such as conditional use approvals.

³ Commercial developments and buildings exceeding 35 feet in height in the R-3A district are subject to the R-4/R-4A site perimeter landscaping standards.

- d. **Visual Enhancement Landscaping**
Visual enhancement landscaping is intended to integrate new or renovated development into the surrounding community and is required along property perimeters that abut another zoning district or a public right-of-way. Landscaping improvements shall be placed within the area identified as the perimeter landscaping area and may be organized to the best advantage of property development.
- e. **Buffer Landscaping**
Buffer landscaping is intended to help separate one land use from another land use that may be incompatible for reasons such as the intensity of use or the visual character.
- f. **Screening Landscaping**
Screening landscaping provides the highest level of buffering between land uses, and is mostly applied by use-specific standards in chapter 21.05 between residential land uses and abutting industrial uses.
- g. **Freeway Landscaping**
Freeway landscaping is intended to enhance the appearance of the municipality along portions of the Seward Highway, the Glenn Highway, and Minnesota Drive/O'Malley Road. Landscaping improvements in these designated areas may be used to screen adjacent uses, such as residential uses impacted by the adjacent roadways, and to enhance the appearance of major visual and scenic corridors and entrance gateways of the community. Freeway landscaping is limited to specific areas along major highways in Anchorage as identified in table 21.07-4: *Landscaping Specifications*.

2. **Parking Lot Landscaping Requirements**

- a. **Purpose**
Parking lot landscaping softens the view and breaks up the visual impact of extensive paved surfaces associated with multifamily residential and nonresidential development. It also contributes to storm water management, provides orientation to entrances, increases outdoor comfort levels, and mitigates wind and dust in large parking lots. Parking lot landscaping consists of parking lot perimeter landscaping and parking lot interior landscaping.
- b. **Parking Lot Perimeter Landscaping**
 - i. Parking lot perimeter landscaping is required for all parking lots with 10 or more parking spaces that are associated with any multifamily or nonresidential use, and for parking lots that are a principal use on a site.
 - ii. Parking lot perimeter landscaping shall be placed on all perimeters of a parking lot, which includes appurtenant driveways, where the parking lot abuts a property line. L2 buffer landscaping shall be used where a nonresidential district abuts a residential district, or is adjacent to a residential district across an alley, and where a multifamily district abuts a single-family residential district. All other sides of the parking lot perimeter shall have L1 visual enhancement landscaping.
 - iii. Exceptions include:
 - (A) At approved points of pedestrian and vehicle access; and
 - (B) Adjacent to lots being developed under a common development plan, where the director waives the requirement.

- (C) Development in the DT districts, which shall follow the parking lot landscaping standards set forth in 21.11.070D.1.

c. **Parking Lot Interior Landscaping**

Parking lot interior landscaping is intended to visually enhance and break up the area of larger parking lots. Parking lot interior landscaping is required for any parking lot with 40 or more parking spaces. The area of the parking lot shall be determined by the total paved area including parking, circulation aisles, and appurtenant driveways. Development in the DT districts is exempt from the requirements in this subsection, and shall instead follow the parking lot landscaping standards set forth in 21.11.070D.1.

i. Parking lot interior landscaping requirements are as follows:

- (A) 40 to 100 parking spaces: An area equal to at least five percent of the parking lot shall be devoted to landscaping.
- (B) 101 to 200 parking spaces: An area equal to at least eight percent of the parking lot shall be devoted to landscaping.
- (C) More than 200 parking spaces: An area equal to at least ten percent of the parking lot shall be devoted to landscaping.

ii. Areas eligible to be counted as parking lot interior landscaping in subsection c.i. above shall be surrounded by parking area and/or driveway on at least three sides, except that up to 50 percent of the total parking lot interior landscaping, up to a maximum of 800 square feet, may include landscaping areas with parking area and/or driveway on only two sides (such as corner areas of parking lots).

iii. For parking lots with more than 200 spaces, a linear landscaping break with a minimum width of 8 feet shall be provided parallel to every third drive aisle. This area may count toward the total interior parking lot landscaping requirement.

iv. Parking lots with more than 200 spaces and exceeding the parking requirements by 25 percent or more shall increase the parking lot interior landscaping area by the amount provided in subsection 21.07.090E.2.d., *Maximum Number of Spaces Permitted – Increased Landscaping in Large Parking Lots*.

v. Fifty percent of the area required for parking lot interior landscaping may be accommodated by biofiltration swales. The use of biofiltration swales to partially fulfill some portion of the need for parking lot interior landscaping requires that swales be a minimum of ten feet in width and designed to promote biofiltration.

3. **Site Enhancement Landscaping**

a. **Purpose**

Site enhancement landscaping provides plant materials to open areas of a site to enhance the appearance and function of the building and site, to help prevent erosion and dust by covering bare disturbed areas, and to help reduce and clean storm water runoff.

b. **Applicability and Requirements**

Development sites shall provide site enhancement landscaping, except that single-family or mobile home dwellings on individual lots are exempt. Site enhancement

landscaping requirements, including required area and planting materials, are provided in table 21.07-4: *Landscaping Specifications*.

4. Trees for Residential Development

a. Purpose

This section establishes a minimum requirement for trees in new residential development. It encourages the retention of existing trees and in general promotes a sustained presence of trees and woodlands for their benefits to property values, community character, wildlife habitat, and the natural environment in urban areas of the municipality.

b. Applicability





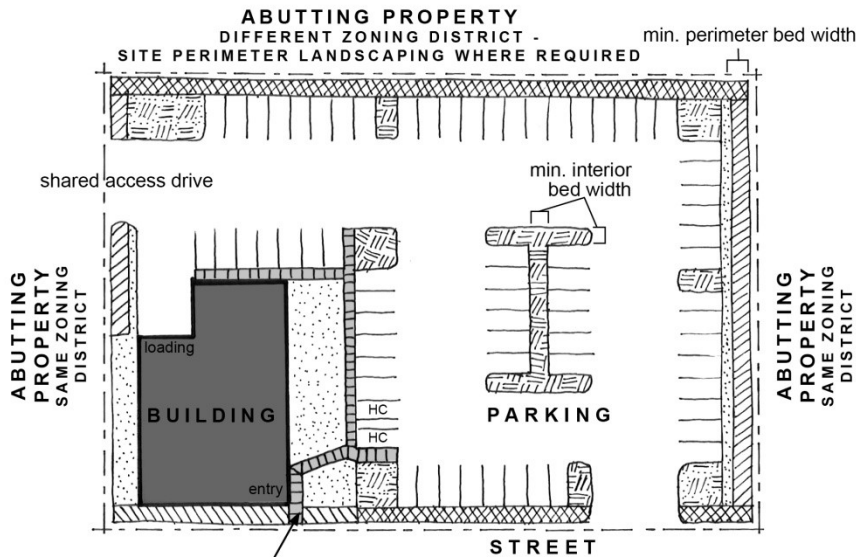

This section applies to new residential development, except for development in the DT districts and single-family and two-family lots that were platted before January 1, 2014.

c. Requirements

All individual lots in a subdivision shall have a minimum of one tree prior to the issuance of a certificate of zoning compliance for the original structure. A minimum of 20 trees per acre is required in new residential developments. Deciduous tree plantings shall be two-inch caliper or greater, and coniferous tree plantings shall be six feet in height or greater. This section may be fulfilled by the preservation of existing trees as provided in subsection F.1.b. below.



walkway counts toward site perimeter landscaping area where crossing bed

-  site perimeter landscaping
-  site enhancement landscaping
-  parking lot perimeter landscaping
-  parking lot interior landscaping
-  site & parking lot perimeter landscaping overlap area
-  site enhancement or parking lot interior landscaping
 Up to half of the total required parking lot interior landscaping area, up to maximum 800 square feet, may include landscaping beds with parking and driveways on only two sides (such as corner areas of parking lots).

Type of Landscaping Areas (Site Plan Example)

F. General Landscaping Requirements and Standards

1. Plant Materials

Anchorage lies generally within the USDA climatic zone 3. This categorization is intended to help identify plants with suitable hardiness to survive in our climate. There are known microclimates within Anchorage that are less severe in some areas and more severe in others. It is not the intent of this title to dictate the use of individual species; however property owners are encouraged to understand the local climate and to use plant species known to be hardy. It is the property owner's responsibility to replace plant materials which are provided in response to the requirements of this title, but perish due to poor maintenance, lack of hardiness, mechanical damage, or some other reason. In all cases, the plant materials shall be living and free of defects and of normal health, height, and spread as defined by the American Standard for Nursery Stock, ANSI Z60.1, latest available edition, American Nursery and Landscape Association. Plants may be nursery grown or native transplants, provided they meet the requirements of ANSI Z60.1.

a. *Minimum Size of Planting Materials*

i. *Trees*

(A) Deciduous trees: 2 inch caliper

(B) Coniferous trees: 6 feet in height

ii. *Shrubs*

(A) Deciduous shrubs: 18 inches in height

(B) Evergreen shrubs: 18 inches in height

(C) Creeping evergreen shrubs: 18 inch spread

b. *Preservation of Existing Plant Material*

This title acknowledges the great benefit of preserving existing mature plant material over the replacement of such material with new immature landscape plantings. The mature landscaping may consist of a mass of native plant materials that include a complete community of trees, shrubs, and ground covers, or it may consist of mature individual tree specimens.

c. *Native Plant Material Mass*

A mass of existing native plant material preserved on site may be utilized to fulfill a portion of the landscaping requirements identified in this title. To fulfill this requirement, existing plant materials shall include trees, shrubs, and groundcovers. The quantity of trees within the stand of native plant materials shall be at least equal to the quantity of trees required for the types of landscaping identified above. Provided that the stand(s) of existing vegetation meet the requirement for the quantity of trees, the area of the stand of existing vegetation shall be equal to at least 50 percent of the total square foot area for which the existing vegetation is fulfilling the landscaping requirement. Use of existing vegetation may be mixed with planted landscaping improvements to fulfill total requirements.

d. *Individual Tree Specimens*

Existing individual tree specimens that are preserved on-site may be used towards meeting the landscaping requirements for visual enhancement, buffer, screening, or freeway landscaping, as identified above, if these trees are located in the applicable site perimeter or parking lot landscaping areas. Retained existing trees that meet the above requirements shall be credited as follows:

i. Coniferous trees 10 feet or more in height are equivalent to three new trees.

native perennial ground covers and wildflowers shall be planted to provide continuous ground coverage within three years.

4. Installation of Landscaping

a. *Timing*

All required landscaping and screening shall be installed by the developer. All landscaping shall be installed before a certificate of zoning compliance is issued. If a certificate of zoning compliance is requested between September 16 and May 31, then the certificate shall be conditioned upon the landscaping being installed before the following September 15. The Director may extend the period in which a certificate of zoning compliance can be requested to later than September 16 if climatic conditions support the survivability of plant materials.

b. *Guarantee of Landscaping Survival*

i. The owner shall be responsible for landscaping installed to fulfill the requirements of this title and the approved site landscape plan. In order to ensure the preservation or replacement of required and installed landscaping, the owner shall provide to the municipality a warranty guarantee such as a letter of credit, escrow, performance bond, or other surety as approved by the director. Single-family and two-family homes and multifamily and townhouse developments with less than five units on individual lots, and lots less than 10,000 sf in area are exempt from providing this guarantee. The warranty guarantee shall be in an amount equal to the following schedule, and shall remain in effect for two years, starting on the date the municipality witnesses the installation per the approved landscape plan.

TABLE 21.07-6: WARRANTY GUARANTEE SCHEDULE	
Lot Area	Value of Surety
10,000-15,000 sf	\$1,200
15,001-20,000 sf	\$1,750
20,001-30,000 sf	\$5,000
30,001-40,000 sf	\$7,500
40,001-50,000 sf	\$10,000
50,001-75,000 sf	\$12,500
75,001-100,000 sf	\$15,000
100,001 sf and greater	\$20,000

ii. At warranty end and prior to the municipality authorizing release of the guarantee, a licensed landscape architect or a certified arborist shall inspect the landscaping. When landscaping is found to be complete and healthy as intended, the inspector shall provide affidavit of the same to the director. At the direction of the above inspector, the owner shall replace failed or failing landscaping with healthy material per the approved landscape plan and to the satisfaction of the inspector. The municipality shall release the guarantee within 30 days of receiving the affidavit of the inspector that all the landscaping is found to be complete and healthy as intended.

5. Maintenance and Replacement

a. Trees, shrubs, other vegetation, irrigation systems, fences, and other landscaping, screening, and fencing elements shall be considered as elements of a development in the same manner as other requirements of this title.

- b. The property owner shall be responsible for regularly maintaining all landscaping elements in good condition. All landscaping shall, to the extent reasonably feasible, be maintained free from disease, weeds, and litter.
- c. Any landscaping element that dies, is removed, or is seriously damaged shall be replaced with the same type and size landscaping element that is shown on the approved landscape plan for the site.
- d. All landscaping, screening, and fencing materials and structures shall be repaired and replaced as necessary to maintain them in a structurally sound condition.

G. Screening

1. Purpose

Screening consists of landscaping, the retention of natural vegetation, or the use of physical structures to block views of specific activities or specific parts of a property or structure.

2. Refuse Collection

In order to improve the appearance of the municipality's streets and neighborhoods, refuse collection receptacles shall be screened and set back from abutting streets in a location where they can be conveniently and safely accessed by the intended users and by refuse collection vehicles, as provided in this section.

a. *Applicability*

The standards of this subsection 21.07.080G.2. shall apply to all outdoor refuse collection receptacles, including dumpsters, compactors, garbage cans, debris piles, and grease containers, except for the following:

- i. Receptacles that receive refuse collection service only from an alley, unless the receptacle is in a DT district.
- ii. Public trash receptacles for pedestrians.
- iii. Public drop-off recycling receptacles, which are subject to the recycling drop-off use-specific standards of subsection 21.05.060E.7.
- iv. Waste receptacles for temporary uses such as construction sites.
- v. Refuse collection receptacles that are stored indoors and brought outdoors on garbage pickup days.

b. *Service Provider Standards*

Approval under this title does not by itself guarantee that a service provider will service the receptacle. Property in the municipal solid waste service area shall also abide by AMC 26.70.050 which requires approval of enclosure plans by solid waste services prior to construction. Other service providers may have similar requirements.

c. *Residential Dwellings*

- i. In class A districts, single-family, two-family, townhouse, and three-unit multifamily dwellings on lots less than 40,000 square feet shall not have dumpsters, except where serviced from an alley.
- ii. In class B districts, dumpsters are permitted and shall be screened in accordance with the standards below.

iii. Where dumpsters are not provided, multifamily developments shall provide covered storage for trash receptacles. Such storage shall not be located between any building and the primary adjacent street frontage.

d. **Site Plans**

Site plans for applicable development shall include the proposed location and type of refuse receptacle screening that will be used and the access provisions for service trucks. If a screening enclosure is necessary pursuant to G.2.f. below, the site plan shall include the construction details of the enclosure to ensure the dimensions comply with the service provider's standards. Site plans with refuse receptacles in alleys shall identify the location of the refuse receptacle and the methods with which the receptacle shall be contained in its identified location.

e. **Location**

Outdoor refuse collection receptacles shall not be located in any required front setback. Outdoor refuse collection receptacles shall be set back from the front plane of the principal structure to the extent reasonably feasible and depending on the size, location, and configuration of the site, and need for access by refuse collection vehicles. Refuse collection receptacles shall not be located within any area used to meet the minimum landscaping or parking requirements and loading berth requirements of this chapter, or be located in a manner that obstructs or interferes with any designated vehicular or pedestrian circulation routes onsite. Refuse collection vehicle access and circulation shall be considered and shown on the site plan, in conformance with subsections 21.07.090D., *Parking Lot Layout and Design Plan*, and 21.07.090H.8., *Vehicle Access and Circulation - General*.

f. **Screening**

Each refuse collection receptacle shall be screened from view from streets and rights-of-way abutting the property, if the receptacle is to be stored within 300 feet of the street or right-of-way. The screening may be achieved by buildings and structures, fences, landscaping, topography, or a refuse collection receptacle screening enclosure.

i. If a screening enclosure is necessary to meet the standards of this subsection, the screening enclosure shall consist of a durable, three-sided screening structure. Screening enclosure construction and dimensions shall comply with service provider industry standards and AMC 26.70.050.

ii. If the refuse collection receptacle is visible through the open side of the required screening structure from the abutting street or right-of-way, the opening shall be screened with a sight-obscuring gate. The enclosure and any gate shall be maintained in working order to function as a screening structure. The gate shall remain closed except on refuse collection days and the prior evening. A sight-obscuring gate is not required for receptacles that receive refuse collection service only from an alley in the DT districts.

g. **Amortization of Nonconforming Refuse Collection Receptacles**

Existing dumpsters that are located at residential uses indicated in subsection 21.07.080G.2.c.i. shall be removed within 18 months from January 1, 2014. Sites with refuse collection receptacles that are subject to the location and screening requirements of this subsection 21.07.080G.2. shall meet the requirements of this section within seven years from January 1, 2014, except where an administrative variance is granted in accordance with subsection 2.h. below. For development in

the DT districts, the threshold date that is applicable to the provisions in this paragraph is May 28, 2020 rather than January 1, 2014.

h. Administrative Variance for Refuse Receptacle Location and Screening

The municipality recognizes that full compliance with the refuse receptacle location and screening standards will not be reasonably feasible for some existing developments approved prior to January 1, 2014. The intent of this subsection is to provide for partial or complete exemption in such cases, through a documented administrative process. The variance should be the minimum action necessary to provide relief, with the intent to encourage existing development to move in the direction of conformity.

i. If a site was developed prior to January 1, 2014, the property owner may apply for an administrative variance from the location and/or screening standards of this section, using the administrative variance procedure of subsection 21.03.240J., subject to the following approval criteria:

- (A) Compliance would conflict with other requirements of this title, or other laws, ordinances, or regulations;
- (B) Compliance would create unsafe access for refuse collection operations or would obstruct or interfere with designated vehicular or pedestrian circulation routes on site;
- (C) A proposed alternative achieves the intent of this section to the same or better degree; or
- (D) The applicant demonstrates that compliance would be incompatible with the existing layout, function, or appeal of the development for its users, such as interference with or proximity to primary pedestrian access, required landscaping, side or rear setbacks and minimum separation from buildings, outdoor activity spaces, snow storage areas, proximity to windows to living spaces, or vehicle access and parking.

ii. For development in the DT districts, the threshold date that is applicable to the provision in subsection i. above is May 28, 2020 rather than January 1, 2014.

3. Service and Off-Street Loading Areas

a. Applicability

This standard is intended to mitigate visual and noise impacts of service and off-street loading areas on abutting residential uses and neighborhoods, and streets. The standards shall apply to all service and off-street loading areas serving nonresidential uses that are visible from a street or a nonindustrial zoning district. Service and off-street loading areas in the DT districts are exempt from this subsection and shall instead comply with subsection 21.11.070D.2.

b. Standard

Applicable non-enclosed service and off-street loading areas shall be screened as follows:

i. A wall or fence at least eight feet high shall be located along at least one exposed edge of the service or loading area that is parallel to vehicles/trailers parked in the service or loading area. The wall or fence shall extend the length of the longest vehicle/trailer anticipated to be parked in the service or loading area.

- ii. Additional landscaping shall be provided along the site perimeter at the location of the service or loading area to visually obscure the area from the abutting street or property.
- iii. An alternate screening plan may be approved by the director if the proposed plan effectively screens the service or loading area from abutting streets and nonindustrial districts.

4. Mechanical and Electrical Equipment

a. *Applicability*

This section applies when it is referenced as a requirement in another section of this title.

b. *General Requirement*

Mechanical and electrical equipment serving a single building shall be screened from view as provided below. This requirement applies to heating, ventilation, and cooling equipment; pumps; generators; and groups of four or more utility meters. The screening requirement does not apply to telecommunications equipment, chimneys, minor vent pipes, wall vents that are flush/near-flush with the building wall, or solar collectors and reflectors. Screening shall comply with AMC title 23 and the access and safety requirements of utilities.

c. *Rooftop Mechanical and Electrical Equipment*

Rooftop mechanical and electrical equipment shall be screened from view of abutting streets and the ground level of residentially zoned lots using the menu choices provided in subsection 4.d. below. If menu choice d.iii. is the only choice selected, then the roof mounted equipment shall also be set back from the roof edge (where the roof meets the façade wall) at least three feet for each foot of height of the equipment.

d. *Mechanical and Electrical Equipment – Other*

All other mechanical and electrical equipment shall be screened from view from abutting streets, except where located more than 40 feet from the street or right-of-way, using one of the following choices, as long as the choices do not conflict with the requirements and standards of the utility companies:

- i. Sight-obscuring landscaping consisting of shrubs, trees, berms, and/or hardscape materials. Other landscaping required by this title, such as perimeter landscaping, may be used if it meets this standard.
- ii. A sight-obscuring fence, wall, or structure that is adequate in height to screen the equipment.
- iii. Wall-mounted utility meter bases and CT cabinets finished in a color that is consistent with other areas of the building façade, unless an alternative color or design is approved by the director.
- iv. Equipment that is disguised, camouflaged, or hidden so that its function as mechanical or electrical equipment is imperceptible to an uneducated eye.

H. Fences

1. *Applicability*

The provisions of this subsection 21.07.080H. shall apply to all construction, substantial reconstruction, or replacement of fences, retaining walls not required for support of a principal or accessory structure, or any other linear barrier intended to delineate different portions of a lot or to separate lots from each other. The provisions of this subsection do

not apply to temporary fencing for construction, emergencies, or special public events or performance areas.

2. Location

A fence may be constructed within property boundaries, or at the lot line, subject to the limitations in this section. No fence shall be installed so as to block or divert a natural drainage flow onto or off of any other property.

3. Maximum Height

Unless specifically required elsewhere in this title for screening fences, fences shall not exceed the maximum heights set forth below. Such maximum heights shall be measured as provided in subsection 21.06.030D.3.b. Unless specifically allowed by this title, no fence shall exceed eight feet in height.

- a. In the R-1, R-1A, R-2A, R-2D, R-2M, R-3, R-4, R-4A, R-5, and R-7 districts:
 - i. Fences in front setbacks shall not exceed four feet in height.
 - ii. Fences in secondary front setbacks that abut a street of arterial or greater classification may be up to eight feet in height.
 - iii. The director may approve a fence in a secondary front setback to be up to six feet in height where the property owner shows that such fence is necessary to block headlights of in-street traffic, the sight distance triangle is preserved, and no direct vehicular access to the street is provided.
 - iv. Fences in side or rear setbacks shall not exceed six feet in height, except where across an alley from or abutting a nonresidential district, in which case the fence may be up to eight feet in height.
- b. In the R-6, R-8, R-9, and R-10 districts, fences in front setbacks shall not exceed six feet in height if the fence is a screening or sight-obscuring fence.
- c. In the B-1A, B-1B, B-3, and R-O districts, fences in front setbacks shall not exceed four feet in height.
- d. In the MC district, fences in front setbacks shall not exceed six feet in height.
- e. Fences in front setbacks in nonresidential districts shall be located interior to any required landscaping.
- f. Enclosures provided as a part of a permitted tennis court, ball field, or other recreational facility shall be exempt from the height restrictions of this section.
- g. Fences enclosing an electrical utility substation shall be exempt from the height restrictions of this section but shall not exceed 10 feet in height. If the electrical utility substation abuts or is within a residential zoning district, all stationary sections of fences built in accordance with this subsection shall be ornamental fences as defined in AMC 21.15.

4. Finished Appearance Outward

Fences along front or secondary front setbacks shall be installed so that the more finished side (i.e., the side with fewer or no visible structural framing or bracing elements) faces outward from the lot on which it is installed.

5. Prohibited Materials

Fences made of debris, junk, or waste materials are prohibited, unless such materials have been recycled and reprocessed into building materials marketed to the general public and resembling new building materials, or unless approved by the director.

(AO 2012-124(S), 2-26-13; AO 2013-117, 12-3-13; AO 2015-82, 7-28-15; AO 2017-55, 4-11-17; 2017-160, 12-19-17; AO 2017-176, 1-9-18; AO 2020-133, 1-14-20; AO 2020-11, 2-25-20; AO 2020-38, 4-28-20; AO 2020-93, 10-1-20; AO 2021-89(S), 2-15-2022; AO 2023-103(S), 12-18-23; AO 2024-24, 4-23-24)

21.07.090 OFF-STREET PARKING AND LOADING

A. Purpose

This section ensures that parking facilities are designed to perform in a safe, efficient manner. It is also the intent of this section to attenuate the visual, environmental, and economic impacts of parking facilities, and encourage other modes of site access. Specific objectives of this section include to:

1. Support the safe and adequate flow of traffic, pedestrians, and service vehicles in adjoining streets;
2. Provide for safe and orderly circulation and parking in parking and loading facilities, and minimize conflicts between pedestrians and vehicles;
3. Provide for better pedestrian movement and encourage alternative modes of transportation consistent with cleaner air and water, greater transportation choice, and efficient infill and redevelopment by reducing expanses of parking;
4. Facilitate bicycle use by providing safe, secure, and convenient bike parking through minimum requirements for the type of bike parking facilities and the amount of bicycle spaces; and
5. Manage the width and frequency of driveways along street frontages to reduce conflicts with traffic and provide space for street snow clearing and storage, on-street parking (where appropriate), and pedestrian facilities.

B. Applicability

1. Generally

- a. The off-street parking and loading standards of this section 21.07.090 shall apply to all development in the municipality, including changes of use. All areas used for off-street parking and loading shall meet the development and design standards of this section 21.07.090.
- b. Except for the off-street loading requirements of subsection 21.07.090G., all other requirements of this section shall apply to Girdwood unless specifically preempted in chapter 21.09.
- c. Except when specifically exempted, the requirements of this section shall apply to all temporary parking lots and parking facilities that are a principal use on a site.

2. Regulation of Parking Space Use

The providers of off-street parking spaces may reasonably control the users thereof by means that may include, but are not limited to, restricting all parking to the users of the facility; parking lot attendants; control gates; tow-away areas; areas for exclusive use by employees, tenants, or staff; areas restricted for use by customers or visitors; and imposing time limitations on users. Fees may be charged for the use of required parking. The municipality may enforce any approved parking plan or restrictions through any of the code enforcement provisions set forth in chapter 21.14, *Enforcement*.

3. Parking Nonconformities

When a site is out of compliance with this section 21.07.090, section 21.13.060, *Characteristics of Use*, applies.

C. Computation of Parking and Loading Requirements

1. Fractions

When measurements of the number of required or allowed parking spaces result in a fractional number after subtracting for parking reductions or alternatives, the fraction shall be rounded as provided in section 21.15.0200., *Fractions*.

2. Multiple Uses

The number of parking spaces is computed based on the uses on the site. When there are two or more uses on a site, the required or allowed parking for the site is the sum of the required or allowed parking for the individual uses.

3. Area Measurements

Unless otherwise specified in table 21.07-8: *Off-Street Loading Berths*, all square footage-based parking and loading standards shall be computed on the basis of gross floor area of the use in question. For the purposes of this section, all gross floor area shall be counted in such measurement, except for floor area dedicated for parking spaces; driveways; circulation aisles; loading areas; or enclosed and isolated floor area exclusively for HVAC mechanical equipment serving the building, provided such area is located in a mechanical penthouse or topmost floor of a multistory building. The traffic engineer may also waive the floor area for HVAC mechanical equipment occupying another story in the building, provided the majority of such story (including the mechanical equipment) is non-habitable floor area.

4. Additional Computation Standards

a. Off-Street Loading Space

Required off-street loading space shall not be included as off-street parking spaces in computation of required or allowed number of off-street parking spaces, unless approved by the traffic engineer.

b. Areas that Do Not Count Toward Maximum Parking Requirements

For the purpose of calculating parking requirements, the following types of parking spaces shall not count against the maximum parking requirement:

- i. Accessible parking spaces;
- ii. Parking spaces set aside for passenger loading including taxi cab stands and ride hailing service spaces, provided that such spaces are not required by the traffic engineer pursuant to subsection 21.07.090I.;
- iii. Vanpool and carpool parking spaces;
- iv. Stacked, tandem, and full-time attendant (valet) parking spaces in conformance with subsection 21.070090H.12.;
- v. User-paid parking such as unbundled parking;
- vi. Parking spaces with electric vehicle supply equipment (ESVE) for EV charging;
- vii. Fleet vehicle parking;
- viii. Parking spaces provided as the required parking for a use on another parcel through a municipally approved shared parking or off-site parking agreement; and
- ix. Parking structures, underground parking, and parking within, above, or beneath the building(s) it serves.

D. Parking Lot Layout and Design Plan

1. Applicability

For all commercial, commercial marijuana, mixed-use, industrial, community, multifamily, and townhouse residential developments that provide off-street parking, the applicant shall submit a parking facility layout, circulation, and design plan for review and approval by the traffic engineer. The plan shall contain sufficient detail to enable the traffic engineer and the director to verify compliance with this section 21.07.090. Subject to approval of the traffic engineer, the parking layout and design plan may be combined with other plans required under this title, such as the landscaping plan required in 21.07.080, *Landscaping, Screening, and Fences*.

2. Minimum Plan Requirements

- a.** The parking facility layout, circulation, and design plan shall be prepared by a design professional and stamped by a professional registered with the Alaska State Board of Registration for Architects, Engineers, and Land Surveyors, except that parking lots with fewer than 20 parking spaces shall be exempt.
- b.** The parking facility layout, circulation and design plan shall include:
 - i.** Location of permanent or temporary snow storage areas with calculations per 21.07.040F.;
 - ii.** Location of required landscaping areas, refuse screening, and fences;
 - iii.** Location of required pedestrian sidewalks and walkways per 21.07.060E. Show dimensions for sidewalk widths and grades with spot elevations;
 - iv.** Off street parking and loading calculation for all uses located on the site per tables 21.07-5 and 21.07-7;
 - v.** Parking space and loading berth locations. Include number of spaces provided, typical space dimensions, and grades per 21.07.090H.;
 - vi.** Where loading facilities or on-site refuse collection are provided, show commercial truck circulation and truck turning radii when required by the traffic engineer;
 - vii.** Show all parking facility circulation patterns including location of curbed end islands at end of parking rows. Provide dimensions for the width of the circulation aisles, and show grades with spot elevations;
 - viii.** Location of accessible parking spaces and access aisles per 21.07.090J.;
 - ix.** Location of passenger loading zones and spaces per 21.07.090I.;
 - x.** Emergency access, fire lanes, and refuse collection;
 - xi.** Vehicle drive-throughs, vehicle queueing spaces and dimensions including vehicle-to-vehicle separation if required per 21.07.090L.;
 - xii.** Number, location and dimensions of bicycle parking spaces if required per 21.07.090K.;
 - xiii.** Driveways to streets and alleys. Provide dimensions for throat width/depth, landing grades, and driveway slope including spot elevations. Show sight distance triangles per the municipal driveway standards;

- xiv. On site traffic control signage and locations. Provide a sign summary table that indicates Sign ID, MUTCD/ATMS sign designation, description, and the direction the sign is facing;
 - xv. Required parking lot lighting locations, lighting calculations, and glare statement, except that parking lots with fewer than 10 parking spaces serving three- and four-unit multifamily uses are exempt from providing a lighting engineering plan; and
 - xvi. Location of significant drainage elements such as manholes, catch basin, and drainage swales.
- c. The traffic engineer shall ensure that provisions have been made for minimum interference with street traffic flow and safe interior vehicular and pedestrian circulation, transit, and parking.

E. Off-Street Parking Requirements

1. Minimum Number of Spaces Required

Off-street parking spaces are not required, except:

- a. Accessible (ADA) parking spaces may be required, as provided in subsection 21.07.090J.;
- b. Passenger loading spaces may be required, as provided in subsection 21.07.090I.;
- c. Bicycle parking spaces may be required, as provided in subsection 21.07.090K.; and
- d. All areas used for off-street parking shall be constructed as parking facilities that meet the standards of section 21.07.090H., *Parking and Loading Facility Design Standards*.

2. Maximum Number of Spaces Permitted

a. Purpose

The purpose of this subsection is to establish an upper limit on the number of parking spaces allowed to promote efficient use of land, enhanced urban design, a safe and walkable pedestrian environment, alternative modes of transportation, and to protect air and water quality. Exceptions and flexibility procedures are provided where the required limit on the number of parking spaces is problematic for a certain use.

b. Applicability

For any use categorized as a community or commercial use in table 21.05-1, *Table of Allowed Uses*, the maximum number of off-street vehicle parking spaces shall be as provided below. Temporary parking, the uses “parking lot, principal use” and “parking structure, principal use”, and uses in the Educational Facility, Parks and Open Areas, Transportation Facility, and Utility Facility use categories are exempt.

c. Maximum Number of Spaces

Developments shall provide a maximum of one parking space per 250 square feet of gross floor area, except as provided in e.

d. Increased Landscaping in Large Parking Lots

Development sites with more than 200 parking spaces shall increase the overall amount of area devoted to parking lot interior landscaping area to an area equal to at least 12 percent of the parking lot, including parking, internal circulation, and

appurtenant driveways. This shall apply to uses which utilize the exceptions offered in subsection 2.e. below.

e. Exceptions

- i. Restaurants, dinner theaters, and bars may provide up to one parking space per 100 square feet of gross floor area. Health services uses may provide up to one parking space per 200 square feet of gross floor area. Community centers, religious assemblies, crematoriums, assembly uses, and entertainment and recreation uses may provide a maximum of 1 parking space per 3 seats or persons in the principal assembly area based on the maximum occupancy provisions of AMC Title 23.
- ii. If application of the maximum parking standard would result in fewer than six parking spaces, the development shall be allowed six parking spaces.
- iii. Exceptions to the maximum parking requirement may be allowed by the traffic engineer and the director in situations that meet all of the following criteria:
 - (A) The applicant provides a parking demand study of similar sites in the municipality that demonstrates that parking demand cannot be accommodated within the maximum number of parking spaces allowed or through parking congestion reduction strategies such as on-street parking, shared parking with nearby uses, or incentives for alternatives to single-occupancy vehicle use; and
 - (B) The request is the minimum necessary variation from the standards.

F. Alternative Transportation Incentives to Reduce Parking Utilization

1. Purpose

Incentivize and improve access to walking, bicycling, ride-sharing, and public transit for residents, employees, and visitors of developments, in order to:

- a. Save development costs through less parking;
- b. Support efficient use of land and development;
- c. Relieve traffic and parking congestion; and
- d. Reduce parking conflicts between neighbors.

2. Applicability

This subsection is effective beginning January 1, 2024, and applies to multifamily developments with 20 or more dwelling units, and commercial and community service developments of 20,000 or more square feet of gross floor area. Affordable housing units and senior housing units are exempt.

3. Standard

Applicants shall select one choice from the alternative transportation incentives in Table 21.07-7: *Alternative Transportations Amenities and Incentives*, or propose an alternative under subsection 4.

TABLE 21.07-7: Alternative Transportation Amenities and Incentives	
Parking Management	
Unbundled Parking	Off-street parking for the use consists only of unbundled parking as defined in 21.15.040.
Parking Cash-out	The non-residential use implements a parking cash-out program as defined in 21.15.040 and informs all employees of the program.
Pedestrian Amenities	
Additional Bicycle Parking	The development provides twice the number of bicycle parking spaces required by subsection 21.07.090K.
Pedestrian Amenities	The development provides two of the following pedestrian amenities from subsection 21.07.060G. that are not otherwise required for the development: enhanced on-site walkway, transit stop or shelter, pedestrian-interactive building, enhanced street sidewalk.
Transportation Programs	
Rideshare Program	The non-residential use participates in a rideshare program that is available to all employees at no cost and provides designated and signed rideshare parking spaces that meet the passenger loading space standards of 21.07.090I.2.
Car Share Program	The residential use sponsors memberships to a car share program as defined in 21.15.040 that is available to all households and provides designated and signed car share spaces.
Free Transit Pass	The employer or property owner sponsors public transit passes cost-free to all employees or residents.

4. Other Alternatives

Applicants may propose a different amenity or incentive to reduce parking utilization or modify any of the strategies shown in table 21.07-7, subject to approval by the traffic engineer and planning director.

5. Recorded agreement

The property owner shall enter into a recorded agreement with the municipality that guarantees the maintenance and continuation of the alternative transportation amenity or incentive. The municipality shall provide the format (template) for the agreement and record the agreement at the district recorder’s office as a covenant that runs with the land.

G. Off-Street Loading Requirements

No building or structure used for any use specified in the loading column of table 21.07-8: *Off-Street Loading Berths*, shall be erected, nor shall any such existing building or structure be altered so as to increase its gross floor area by 25 percent or more, without prior provision for an off-street loading berth in conformance with the following minimum requirements:

1. Types of Loading Berths

Required off-street loading shall be provided in berths that conform to the following minimum specifications:

- a. Type A berths shall be at least 60 feet long by 10 feet wide by 14 feet six inches high, inside dimensions.
- b. Type B berths shall be at least 30 feet long by 10 feet wide by 14 feet six inches high, inside dimensions.
- c. Type C berths shall be located in the rear of a lot and utilize part of an adjacent alley. The building setback shall be a minimum of five feet from the property line along the alley for the entire width of the lot.

2. Number of Spaces

The following numbers and types of berths shall be provided for the specified uses in table 21.07-8, *Off-Street Loading Berths*; provided, however, that, in any DT district, or in any mixed-use development where an alley is available that is not shared with any adjacent R-1, R-1A, R-2A, R-2D, R-2M, or R-3 zoned residential lot, one type C berth may be substituted for one type B berth. The uses specified in this subsection shall include all structures designed, intended, or arranged for such use.

TABLE 21.07-8: OFF-STREET LOADING BERTHS			
Use	Aggregate Floor Area (square feet) or Number of Dwelling Units	Gross Berths Required	Type
Residential Uses			
Multifamily and mixed-use dwellings	50-149 dwelling units in a structure	1	B
	150-249 dwelling units in a structure	2	B
	Each additional 100 dwelling units or portion thereof	1 additional	B
Group housing	Same as for health care facilities		
Community Uses			
Community center or religious facility	Same as for assembly uses		
Government administration and civic facilities	Same as for office commercial uses		
Cultural facilities	24,000--50,000	1	B
	50,001--100,000	2	B
	Over 100,000, each additional 50,000 or fraction thereof	1 additional	B
Educational facilities	Over 25,000	1	B
Health care facilities	25,000--100,000	1	B
	Over 100,000	2	B
Railroad freight terminals and other transportation facilities, utility facility	12,000--36,000	1	A
	36,001--60,000	2	A
	60,001--100,000	3	A
	Each additional 50,000 or fraction thereof	1 additional	A
Commercial Uses			
Assembly uses, entertainment and recreation uses	25,000--150,000	1	B
	150,001--400,000	2	B
	Each additional 250,000 or fraction thereof	1 additional	B
All commercial establishments not otherwise specified	10,000 --24,000	1	B
	24,001--50,000	2	B
	50,001 – 100,000	3	B
	Over 100,000, each additional 50,000 or fraction thereof	1 additional	B

TABLE 21.07-8: OFF-STREET LOADING BERTHS			
Use	Aggregate Floor Area (square feet) or Number of Dwelling Units	Gross Berths Required	Type
Visitor accommodations, animal sales and service, office, personal services, repair and rental uses	25,000 – 40,000	1	B
	40,001 – 100,000	2	B
	Each additional 100,000 or fraction thereof	1 additional	B
Entertainment Facility (Major), Grocery or Food Store	10,000 – 50,000	1	B
	50,001 – 100,000	2	B
	Each additional 100,000 or fraction thereof	1	A
Marijuana Uses			
Marijuana cultivation facility	12,000 – 60,000	1	B
	Each additional 60,000 or fraction thereof	1 additional	B
Marijuana manufacturing facility	Same as for marijuana cultivation facility		
Marijuana retail facility	Same as for general commercial establishments		
Industrial Uses			
Light contractor and special trades, dry cleaning establishment, commercial food production, and self-storage facility	Same as for general commercial establishments		
Data processing facility, research laboratory, and government services	Same as for office and personal service uses		
All industrial uses not otherwise specified	12,000--36,000	1	A
	36,001--60,000	2	A
	60,001--100,000	3	A
	Each additional 50,000 or fraction thereof	1 additional	A

1

3. Uses Not Specifically Mentioned

In the case of a use not specifically mentioned in this section, the requirements for off-street loading berths shall be the same as the use mentioned in this section which, in the opinion of the director, is most similar to the use not specifically mentioned.

4. Concurrent Different Uses

When any proposed structure will be used concurrently for different purposes, the loading requirements shall be the total requirements for each use based upon its aggregate gross floor area, unless otherwise approved by the traffic engineer and the director.

5. Location of Off-Street Loading Facilities

Off-street loading facilities required under this title shall be in all cases on the same lot or parcel of land as the structure they are intended to serve, except as provided in subsection 21.07.090G.1.c. for type C loading berths. Where parking facilities are not allowed between a building and a street, loading berths are also not allowed.

6. Manner of Using Loading Areas

No loading berth shall be so located that a parked vehicle or tractor-trailer using such loading berth projects into any street or across a required pedestrian facility or sidewalk. Loading berths shall be provided with access to an alley, or, if no alley abuts the lot, with access to a street. Any required front, side, or rear setback may be used for loading unless otherwise prohibited by this title. Design and location of entrances and exits for required off-street loading berths shall be subject to the approval of the traffic engineer.

7. Signs

The owners of the property shall provide, locate, and maintain loading signs as specified by the traffic engineer. Such signs shall not be counted against allowed advertising sign area or number.

8. Modifications

The traffic engineer may approve a modification to the loading requirements as they apply to any individual case if documentation demonstrates to the satisfaction of the traffic engineer that the change is appropriate, will not interfere with pedestrian or vehicle traffic circulation or safety, and is consistent with the intent of the requirements. The traffic engineer shall set conditions on approval of modifications as necessary to ensure that loading operations conform to the intent of this title.

H. Parking and Loading Facility Design Standards

1. Purpose

The parking and loading facility design standards promote vehicle areas which are safe, efficient, convenient, and attractive for motorists and pedestrians. Parking facility locations within a site are encouraged to be located elsewhere than the front area between the building and its street frontage, in order to enhance the function, character, and walkability of the area. These design standards also enhance the compatibility of parking and loading facilities with their surroundings.

2. Applicability

These standards apply to all area used for off-street parking, and any parking facility or loading facility in a development, except where stated otherwise. A temporary parking lot shall comply with all applicable development requirements of this title for surface parking lots and parking lot landscaping, except when associated with another temporary use permitted pursuant to section 21.05.080.

d. The intent of this provision is for areas that will be used as parking and loading facilities to be clearly identified on the site plan and meet the parking and loading facility development standards. Areas of the site accessible to motor vehicles from parking and loading facilities, driveways, or streets shall be separated from those facilities by a physical barrier to prevent motor vehicle access, or the municipal decision-making body may require them to comply with this section 21.07.090H. The physical barrier shall be concrete curbs or an alternate barrier at least six inches in height capable of maintaining separation between vehicles and adjacent areas.

3. Landscaping and Screening

Parking and loading facilities shall comply with the landscaping and screening provisions of section 21.07.080. If the loading facilities are adjacent to the lot line, a maximum of 35 percent of one side of the loading area perimeter landscaping and the site perimeter landscaping may be replaced by a screening fence of a minimum height of six feet. That area for the proposed screening fencing shall only be located where adjacent to a loading area and/or dumpster screening area, and shall not be located adjacent to a residentially zoned parcel or a street. Provisions for location and screening of refuse containers and other elements are in section 21.07.080. No automobile or bicycle parking facility or

loading facility shall be permitted in any required landscaping area. No vehicle overhang allowance area, as measured in table 21.07-9: *Parking Angle, Stall, and Aisle Dimensions*, may extend into the minimum required planting bed width of required landscaping. See figures that follow.

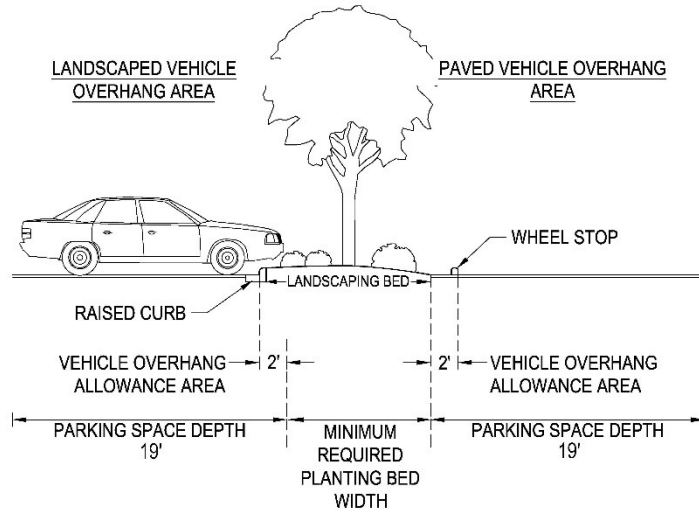

VEHICLE OVERHANG AND REQUIRED LANDSCAPING
 SECTION VIEW (90° ANGLE PARKING SPACE)

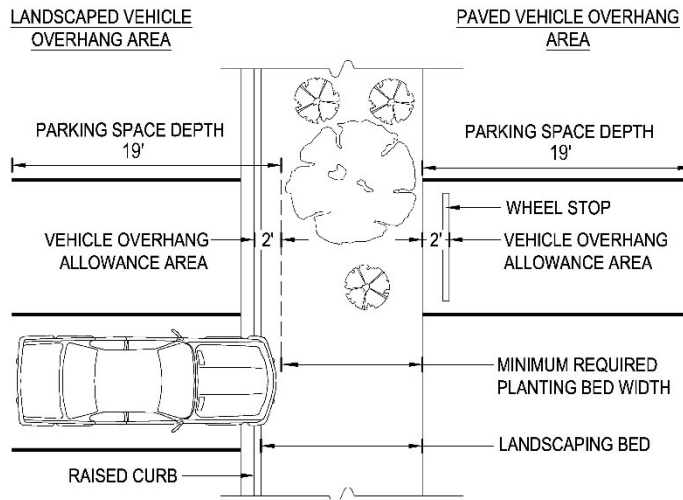

VEHICLE OVERHANG AND REQUIRED LANDSCAPING
 PLAN VIEW (90° ANGLE PARKING SPACE)

4. **Drainage and Storm Water Management**
 Parking and loading facilities shall comply with the parking and loading related provisions of section 21.07.040, *Drainage, Storm Water Treatment, Erosion Control, and Prohibited Discharges*.
5. **Exterior Lighting**
 Parking and loading areas shall comply with the exterior lighting provisions of section 21.07.100.

6. Pedestrian Access and Circulation

Parking and loading facilities shall comply with the provisions of subsection 21.07.060E., *Pedestrian Facilities*. No vehicle overhang allowance area, as measured in table 21.07-7, may extend into the minimum required dimension of required walkways, pedestrian areas, or private open space. See figure that follows.

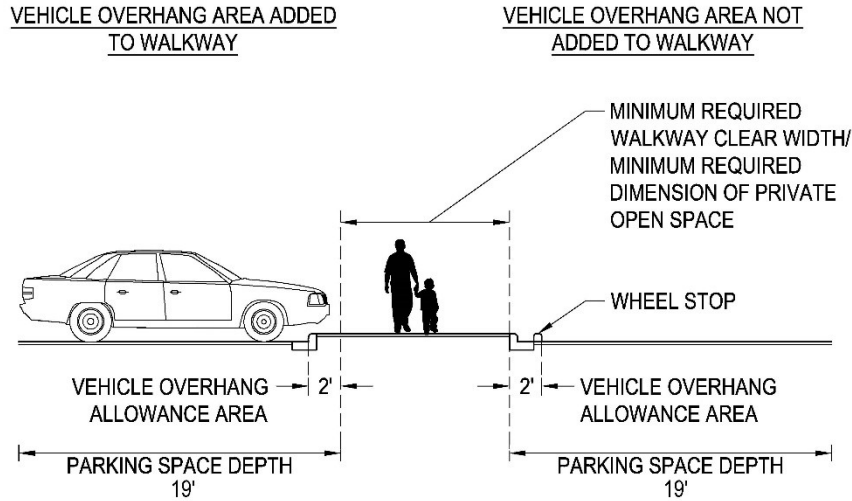

VEHICLE OVERHANG AND REQUIRED PEDESTRIAN FACILITIES

7. Relationship to Buildings

a. Nonresidential Buildings

Parking spaces and parking aisles shall be separated from any nonresidential building by a walkway or site enhancement landscaping planting area, or both, of at least four feet in width. Other motor vehicle areas shall also be subject to this requirement only where the traffic engineer determines it necessary for a safe pedestrian walkway route between a building entrance or parking lots. Otherwise, loading berths, rear service areas, motor vehicle entrance and service bays, queuing lanes, and drive-throughs are exempt.

8. Vehicular Access and Circulation – General

Parking lots and structures access, layout, and dimensions shall be designed for a safe and orderly flow of traffic throughout the site, as provided in subsections 9. through 12. that follow. Vehicular access and circulation patterns and the location and traffic direction of all circulation aisles, driveways, and queuing lanes shall be designed and maintained in accordance with accepted principles of traffic engineering and safety as determined by the traffic engineer.

9. Vehicular Access Location

a. Street Access Location

The number and spacing of driveways, including minimum distance from street intersections, shall be as provided in the *Municipal Driveways Standards* and this section. Access to streets owned by the state of Alaska requires compliance with state driveway standards, and department of transportation and public facilities approval and driveway permit.

b. Alley Access Requirement

Where a residential use is served by an alley and is within an area subject to the Urban Neighborhood Development Context Standards (21.07.010E.), vehicle access shall take place from the alley, except for direct vehicle access to the street that is limited to the following:

- i. One driveway no wider than 12 feet at any point, except that lot frontages 100 feet or wider on a primary street frontage may have one driveway per 50 feet of lot frontage on that street.
- ii. One additional driveway no wider than 12 feet providing access to the secondary street frontage on corner lots for multifamily, townhouse, or two-family developments.
- iii. The director and traffic engineer may approve an administrative variance from the requirements of this subsection, as provided in 21.03.240J.7.

c. *Cross-access and Shared Access with Adjacent Sites*

Parking facilities serving a site, whether located on that same lot or on an adjacent lot, may be connected by means of a common access driveway within or between the interior of such lots. Where a property receives its access to the street through a shared driveway with another lot, a shared access easement shall be provided on the plat, or a shared access agreement running with the land shall be recorded by the municipality, as approved and executed by the director, guaranteeing the continued availability of the shared access between the properties.

d. *Paired Residential Driveways Allowed*

Driveways for two single-family, two-family, or townhouse units may be attached across a property line, provided the maximum combined width of the driveway is 28 feet and other standards of this section are met.

e. *Garage Door Setbacks*

Street-facing garage bay doors that are proposed to be set back from the public right-of-way by less than the length of a standard parking space (as defined in table 21.07-9, *Parking Angle, Stall, and Aisle Dimensions*) shall be reviewed and approved by the traffic engineer, unless there is a sign posted for “no parking”. Garages shall be set back from public rights-of-way including alleys by at least four feet unless the traffic engineer approves otherwise, to ensure adequate sight distance for turning and maneuvering.

f. *Loading Berth Access*

Vehicle maneuvering for loading berths shall be subject to the requirements of subsection 21.07.090G.7., *Manner of Using Loading Areas*.

10. *Access to Parking Spaces*

a. *Access to Parking Spaces*

Each parking space shall open to a parking aisle or driveway of such width and design as provided in subsection 21.07.090H.12. to provide safe and efficient means of vehicular access with no more than a standard two-movement entrance or exit from the parking space and without having to move another vehicle. Stacked and tandem parking spaces are allowed exceptions as provided in 21.07.090H.12.

b. *Backing Distances*

Adequate ingress and egress to each parking space shall be provided without backing more than 25 feet.

c. *Dead-End Parking Aisles*

Any parking bay that does not provide two means of vehicle egress shall provide, at the closed end, an extension of the parking aisle at least nine feet in depth, designated and signed as a “no parking” turn-around area. Dead-end parking bays longer than 100 feet shall be subject to discretionary review and approval by the traffic engineer.

d. Vehicle Maneuvering

Off-street parking facilities shall be designed so that all vehicle maneuvers occur on the development site and not in the public right-of-way, and vehicles enter and exit the right-of-way in a forward motion, except the following are exempt:

- i. Parking for single-family, two-family, and mobile home dwellings on individual lots, accessing a local street.
- ii. For other developments, parking comprising only one or two parking spaces whose only access is to a local street, provided that the vehicle area occupies no more than 20 feet of the lot frontage in the front setback. The number of spaces may be increased to four spaces if arranged in tandem for residential dwellings as provided in 21.07.090K.12.k. Additional spaces for multifamily developments with up to four dwelling units may be approved by the traffic engineer in appropriate circumstances such as lots on dead-end streets, cul-de-sacs, or other local streets with low traffic volumes.

Vehicle Maneuvering Exceptions:

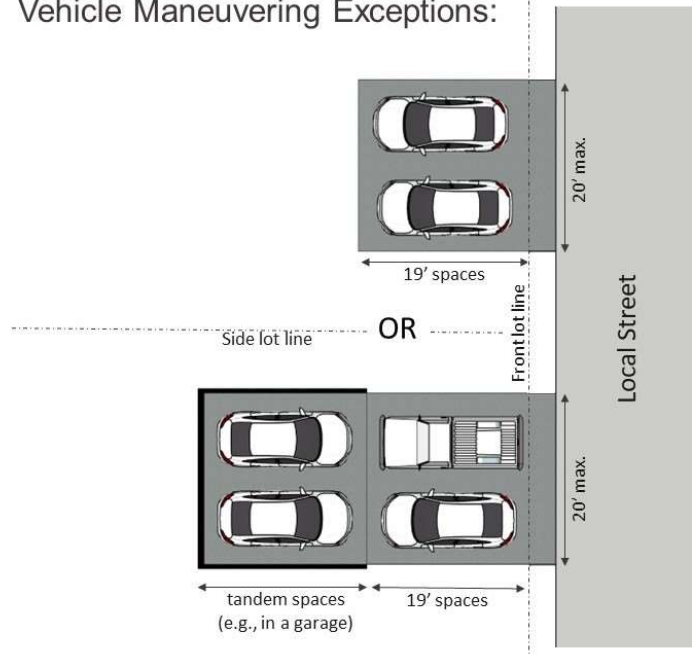

- iii. The usable portion of an alley may be credited as circulation and/or parking aisle space for parking areas. The maneuvering area between the end of the parking space and the opposite side of the improved alley shall meet the parking aisle width in table 21.07-9, *Parking Angle, Stall and Aisle Dimensions*.

11. Driveway Design and Dimensions

a. Parking Lot Entries/Driveway Approaches

Entries and driveway approaches providing access from the street edge to the front property line shall conform to the municipal driveway standards and this section

21.07.090H.11. Access to streets owned by the state of Alaska requires compliance with state driveway standards, as provided in 21.07.090H.9.

b. Curb Openings and Public Walkway Crossings

- i. Curb cuts and curb returns at driveway openings to the street shall be provided as prescribed in the municipal driveway standards.
- ii. Public walkways shall be maintained or restored to the maximum running slope and cross-slope prescribed by M.A.S.S. and A.D.A., except that in areas subject to the urban neighborhood context standards (21.07.010E.), public walkways on local streets shall be restored to a level running grade to the extent reasonably feasible.

c. Driveway Approach (in ROW) as a Percentage of Lot Frontage Width

The total width of driveway approach from a street shall not exceed 40 percent of the frontage of the lot, or 33 percent of the frontage if the platting authority or traffic engineer finds that conditions warrant it, provided the following:

- i. The driveway approach is always allowed to have the minimum driveway width provided by subsection d. The traffic engineer may approve more than the minimum driveway width, provided the traffic engineer determines that snow storage, on-street parking, traffic flow and safety, and the neighborhood context are addressed.
- ii. The driveway approach shall not exceed the maximum driveway width established in the municipal driveway standards.
- iii. Flag lots are exempt from the percentage limitations but shall have a maximum driveway approach width of 20 feet. Abutting flag lots may share a driveway approach up to 24 feet wide (12 feet per lot).

d. Minimum Driveway Width

The minimum required width of driveways including the driveway approach within the street ROW and the portion of the driveway on the development property is as follows:

- i. The minimum width of parking aisles shall be as set forth in 21.07.090H.12.
- ii. The minimum width of the driveway approach shall be as set forth in the municipal driveway standards, except as modified or clarified by subsections iii. through vi.
- iii. The minimum width of a driveway providing access to a single-family, two-family, townhouse, mobile home, or other individual dwelling from a local street or alley is 12 feet.
- iv. The minimum width of a driveway providing access for up to 10 parking spaces serving a townhouse or multifamily residential use from a local street or alley is 12 feet, except that straight (non-curving) driveway segments on the development property (i.e., not in the driveway approach) may be 10 feet.
- v. The minimum width of a driveway providing access for more than 10 parking spaces serving a townhouse or multifamily use from a local street or alley is 12 feet for one-way traffic and 20 feet for two-way traffic.

vi. The traffic engineer may reduce the driveway width to relieve hardship on small or narrow lots or increase the required width to meet vehicle turning and maneuvering needs, in accordance with accepted principles of traffic engineering and safety as determined by the traffic engineer. Minimum driveway widths are also subject to other applicable codes, including the Fire Code.

e. ***Driveway Throat Length***

The driveway throat shall be of sufficient length to enable the street and walkways in the ROW and the circulation, parking, and walkways in the development site to function without interfering with each other, as provided in the municipal driveway standards.

f. ***Sight Distance***

Ingress and egress to parking facilities shall be designed as prescribed in the municipal driveway standards to maintain adequate site distance and safety.

g. ***Circulation Definition***

Circulation patterns within parking facilities shall be well defined with pavement marking and signage, curbs, landscaping, and/or other similar features. Curbed end islands shall be provided at the end of each row of parking spaces to define circulation and provide sight distance at internal intersections of parking aisles, driveways, and/or on-site roadways. Shared parking courtyards meeting 21.07.060G.23. may depart from this requirement.

12. Dimensions of Parking Spaces and Aisles

The parking space and aisle dimensional standards of this subsection 21.07.090H.12. shall apply to all parking except as stated otherwise in subsections 21.07.090I., *passenger loading zones* and 21.07.090J., *accessible parking spaces*. Parking dimensions and layout shall be as provided in subsection a., including Table 21.07-9: *Parking Angle, Stall, and Aisle Dimensions* and the figures that follow the table, with the additions and exceptions provided in subsections b. through m.

a. ***Minimum Dimensions for Parking***

Parking shall meet or exceed the STANDARD parking space and aisle dimensions set forth in table 21.07-9, except as follows:

i. Up to 30 percent of parking in the Downtown (DT) zoning districts may meet the COMPACT parking dimensions set forth in table 21.07-9, if signed for compact vehicles only.

Parking Angle (Degrees)	Parking Space Size	Space Width	Curb Length (Width Projection)	Space Depth (Vehicle Projection)	Aisle Width 1-way	Aisle Width 2-way	Interlock Reduction	Overhang Allowance
90	STANDARD	9' 0"	9' 0"	19' 0"	23' 0"	24'	0' 0"	2' 0"
	COMPACT	8' 0"	8' 0"	16' 0"	23' 6"	24'	0' 0"	
75	STANDARD	9' 0"	9' 4"	20' 8"	19' 0"	24'	1' 2"	1' 11"
	COMPACT	8' 0"	8' 3"	19' 5"	19' 6"	24'	0' 6"	
60	STANDARD	9' 0"	10' 5"	20' 11"	18' 0"	24'	2' 3"	1' 8"
	COMPACT	8' 0"	9' 3"	17' 10"	18' 6"	24'	1' 0"	
45	STANDARD	9' 0"	12' 9"	19' 6"	12' 0"	24'	3' 2"	1' 5"
	COMPACT	8' 0"	11' 4"	16' 12"	12' 6"	24'	1' 5"	
0 (parallel)	STANDARD	9' 0"	23' 0"	9' 0"	12' 0"	24'	0' 0"	0' 0"
	COMPACT	8' 0"	23' 0"	8' 0"	12' 6"	24'	0' 0"	

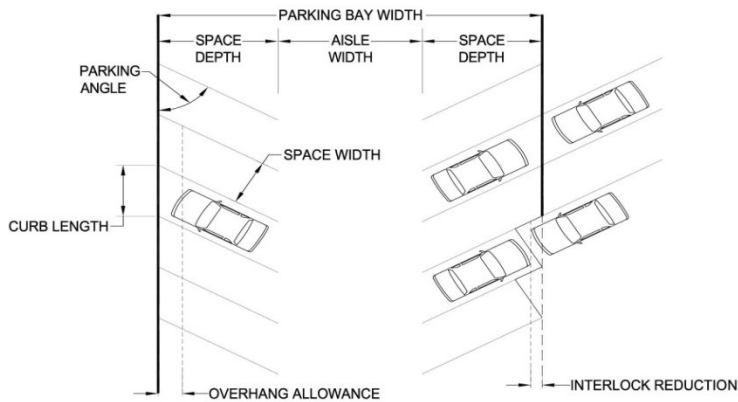

PARKING DIMENSIONS

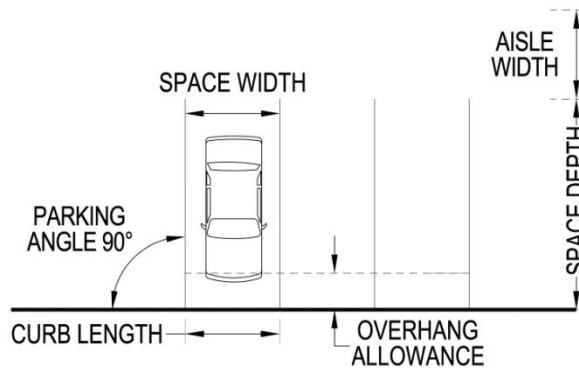

90° PARKING SPACES

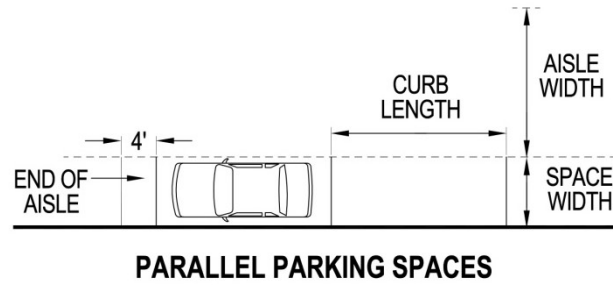

PARALLEL PARKING SPACES

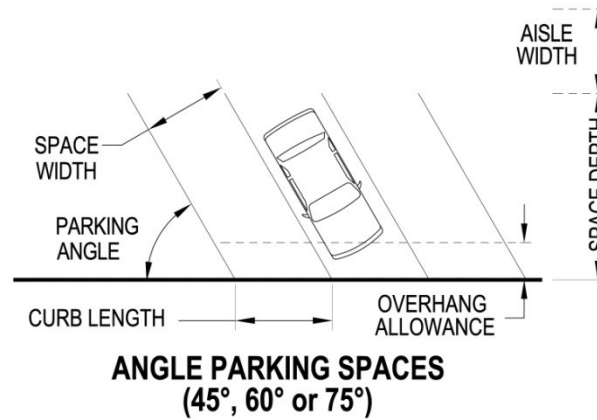

**ANGLE PARKING SPACES
(45°, 60° or 75°)**

- b. *Parking Angle***
 Parking angles between zero and 45 degrees and between 75 and 90 degrees are not permitted, except as approved by the traffic engineer. Angles between 45 and 75 degrees are permitted. The dimensions for such angles shall be calculated by the applicant using a method prescribed by the traffic engineer. The angle parking spaces diagram above, including the elements of a parking space that it depicts relative to the required space dimensions in table 21.07-9, are equally applicable to either front-in or back-in angle parking spaces.
- c. *Parking Aisle Width***
 Where the parking angle differs across a one-way parking aisle, the greater required parking aisle width shall be provided. In the case of on-street parking, the parking aisle width is replaced by the street's travel lane, and municipal street standards for street lane widths apply.
- d. *Reduction in Parking Space Depth Due to Interlock***
 Parking space depth (vehicle projection) may be reduced through the use of interlock between angled parking bays as shown in the parking dimensions figure. The amount of reduction in the parking space depth shall be as provided in the interlock reduction column of table 21.07-9. The parking angle of the abutting parking bays shall be equal in order to use the interlock reduction.
- e. *Overhang Allowance with a Parking Space***
 The maximum overhang allowance shall be as shown in table 21.07-9 and the figures that follow it. The distance between the end of the parking space and the face of any raised curb or wheel stop used in the parking space shall be equal to (no greater or less than) the overhang allowance provided in table 21.07-9. The

relationship between the overhang allowance and adjacent required landscaping and pedestrian facilities is established in subsections 21.07.090H.3. and H.6. Surfacing options for the overhang allowance area of the parking space are provided in subsection 21.07.090H.12.b.v., *Paving Exceptions and Alternatives*.

f. *Parking Spaces Abutting a Wall, Fence, or Other Obstruction*

Minimum required parking space dimensions shall be clear of all obstructions, other than wheel and curb stops and structural columns that meet the requirements of subsection 9.g. below. When the length of a parking space abuts a wall, fence, or other obstruction, the required width of the parking space shall be increased by one foot for each side with an obstruction. The parking space angle and dimension requirements shall apply to the inside dimension of a parking space abutting an obstruction.

g. *Structural Columns*

A structural column may encroach into the width of a parking space by up to one foot, provided the remaining parking space width is no less than eight feet. Such column shall be located within four feet of either end of the parking space depth. Such column shall not be located within one foot of the drive aisle.

h. *Minimum Vertical Clearance*

A minimum height of 14 feet shall be maintained clear of obstructions from any parking lot surface to any structure or landscape feature above that may interfere with the safe passage of vehicles. The minimum vertical clearance for a structured parking facility, carport, or garage shall be seven feet four inches, except as follows:

- i. The minimum vertical clearance for van accessible parking spaces, access aisles serving them, and vehicle routes to the van accessible spaces shall be eight feet two inches.
- ii. The minimum vertical clearance for passenger loading zones including vehicular pull-up spaces, access aisles serving them, and a vehicular route between an entrance and exit and the passenger loading zone shall be nine feet six inches.

i. *Recreational Vehicle Spaces*

Parking spaces for recreational vehicles, if provided and delineated, shall be a minimum of 10 feet wide by 40 feet long.

j. *Stacked or Tandem Spaces with Attendant Parking*

The traffic engineer may approve reduced parking space dimensions for stacked parking spaces and/or tandem spaces in an attendant (valet) parking facility. An accessible passenger loading zone shall be provided with attendant (valet) parking services at or near a primary entrance. Notice of availability of valet service shall be conspicuously posted inside and outside the primary entrance. The business owner shall enter into a parking agreement with the municipality guaranteeing continuation of the valet service.

k. *Stacked or Tandem Spaces for a Residential Dwelling*

Two parking spaces for any residential dwelling may be arranged in tandem with a combined space depth (vehicle projection length) of 38 feet, or stacked one above the other using a car stacker, subject to the following:

- i. The parking for the dwelling unit is arranged independently from parking serving any other dwelling unit; and
- ii. The owner assigns the two spaces to the same dwelling.

- I. *Automated Parking Structures***
Automated parking structures are exempt from the parking space and aisle dimensions and vertical clearance requirement of this section 21.07.090H.12. They are instead subject to section 21.07.090M.10.
- m. *Administrative Adjustments***
The traffic engineer may approve a lesser parking dimension than set forth in this subsection 21.07.090H.12., due to site topography, existing structures, lot configuration, or preservation of trees and vegetation, subject to a recorded parking agreement.
- 13. *Parking Facility Maintenance***

 - a.** Paved surface parking lots with 20 or more spaces shall be cleaned annually, or as otherwise required by the current MS4 permit, including once following spring melt prior to June 1 or as snowmelt conditions permit, in a manner that meets air quality and water quality standards.
 - b.** On-site storm water detention and runoff facilities serving parking facility runoff shall be cleaned and maintained in a functional manner, or as otherwise required by the current MS4 permit.
 - c.** Grit or oil and water separator devices shall be cleaned and maintained in a functional manner, or as otherwise required by the current MS4 permit.
- 14. *Maximum Grade of Surface Parking Lots***
The maximum grade for any parking space or circulation aisle shall be five percent, except that for accessible spaces the maximum grade shall be two percent, as required by the Americans with Disabilities Act. Circulation aisles that are covered or heated may have an increased maximum grade with the approval of the traffic engineer.
- 15. *Paving***

 - a. *Material***
Except as provided below, all parking spaces, loading berths, driveways, and other motor vehicle driving surfaces shall be paved and maintained with dustless, all-weather, hard materials appropriate for the municipality's sub-arctic environment, and equal in strength to two inches municipal Type E asphaltic concrete and a base material suitable for the intended traffic, to standards prescribed by the municipal engineer or as otherwise approved by the traffic engineer.
 - b. *Paving Exceptions and Alternatives***
The traffic engineer may approve the following exceptions and alternatives to the paving requirement, provided that the first 50 feet of a driveway, as measured from the edge of the street travelled way, shall be paved if connecting to a paved public street. This length is reduced to 15 feet for single-family and two-family uses. Where a driveway throat is less than 50 feet, the traffic engineer may approve an alternative driveway surface that effectively reduces or eliminates the tracking of sediment onto paved public streets.

 - i. *Use-Specific Exceptions***
Certain uses may use gravel in lieu of paving, as specified in chapter 21.05.
 - ii. *Exceptions for Small Parking Lots in Class B Districts***
Parking lots of 10 spaces or fewer in class B districts may instead be surfaced with a layer of crushed rock of no more than one inch in diameter, to a minimum depth of three inches.
 - iii. *Exceptions for Some Vehicle Storage Areas***

The following areas need not be paved: outdoor vehicle storage areas associated with a self-storage facility use; storage, sales, or rental of heavy equipment; seasonal large vehicle storage; and tractor trailer storage areas not used for loading berths, loading berth maneuvering, access to bay doors, site access, or parking. Such areas are still subject to the drainage requirements of subsection 21.07.040.

- iv. *Exceptions for Parks and Open Spaces*
Subject to review and approval by the traffic engineer, some parking spaces for parks facilities that are demonstrated to have a highly variable seasonal demand need not be paved.
- v. *Paving Alternatives*
Pervious alternatives to the specified surface may be used, subject to approval by the traffic engineer. All surfacing shall control dust, treat storm water to municipal standards, and be such that rock and other debris is not tracked off-site. If, after construction, the traffic engineer determines that the alternative is not adhering to these requirements, the surface shall be replaced.
- vi. *Landscaping in Lieu of Paving*
The vehicle overhang allowance portion of the parking space depth as measured in table 21.07-9: *Parking Angle, Stall, and Aisle Dimensions*, and illustrated in the figures following the table, may be landscaped with a low-growth, hardy plant material in lieu of paving, allowing a bumper overhang while maintaining the required parking dimensions. Landscaped overhang allowance areas may be contiguous with required landscaping but shall not be counted toward the minimum required planting bed width.
- vii. *Exception for Temporary Parking Lots*
Temporary parking lots associated with another temporary use pursuant to section 21.05.080, need not be paved, unless required by the traffic engineer.
- viii. *Exception for Paving if Property is Accessed by an Unpaved Alley or Unpaved Local Street.*
If a property is accessed by an unpaved alley or street with local classification, the owner may construct permitted driveways using crushed rock or other suitable compactible material in lieu of paving.
- ix. Residential driveways to local streets in Turnagain Arm may be surfaced with a layer of crushed rock to include the area of the apron, as indicated by the boundaries of the Turnagain Arm Comprehensive Plan.

I. **Passenger Loading Zones**

All institutional, entertainment, and commercial uses such as schools/daycare, stadiums, and theaters that have high-volume peak traffic volumes shall provide an area for drop-offs and pick-ups that meets the following requirements:

1. **Passenger Loading Zone**

The traffic engineer may require one or more passenger loading zone spaces, depending on the type, intensity, and traffic patterns of the proposed use. The passenger loading zone for large commercial establishments or other intensive uses may be required by the traffic engineer to include one or more spaces dedicated to taxi cabs, ride hailing services, and/or other specialized high occupancy vehicles.

2. Passenger Loading Zone Dimensions

Any passenger loading zone that is provided for a development shall consist of one or more passenger drop-off/pick-up spaces parallel to the driveway or circulation aisle adjacent to the building. Each space shall be a minimum of 20 feet in length and eight or more feet in width, with an access aisle at least five feet wide abutting the full length of the space. As an alternative, subject to approval of the traffic engineer, a passenger loading zone may consist of one or more parking spaces that meets the accessible parking space dimensional standards of subsection 21.07.090J.8. However, designated passenger loading zone spaces shall not count towards any accessible parking space requirement.

3. Plan

The parking facility layout, circulation, and design plan shall show the location and design of proposed passenger loading zones. For certain intensive uses, the traffic engineer may require the plan to include a traffic control plan addressing projected usage, hours of operation, peak loading/unloading time, plans for directing traffic, safety measures, and other information deemed necessary by the traffic engineer to designing a safe and well-functioning drop-off area.

4. Accessible Route

An accessible pedestrian route to the building or facility entrance shall be provided pursuant to subsection 21.07.090J.10., *Accessible Routes*.

5. Schools

Passenger loading zones shall be required for schools (public or private). Length, location, and design of the passenger loading zones shall be approved by the traffic engineer.

J. Accessible Parking Spaces

1. Required Number of Accessible Parking Spaces

A portion of the total number of parking spaces provided in each parking facility for commercial, industrial, community, multifamily, and mixed-use residential uses shall be accessible parking spaces. These requirements are intended to reflect current national data on prevalence of mobility disabilities. However, buildings in multifamily or mixed-use developments that are single-family, two-family, or townhouse style structures are not subject to the accessible parking space requirement. The number of accessible parking spaces shall be determined based on the total number of parking spaces provided, in accordance with table 21.07-10, *Accessible Parking Spaces*, except where otherwise stated in this section.

TABLE 21.07-10: ACCESSIBLE PARKING SPACES		
Total Parking Spaces Provided	Total Accessible Spaces Required	Number of Accessible Spaces that shall be Van-Accessible
1 to 10	1	1
11 to 25	2	2
26 to 50	4	2
51 to 75	6	2
76 to 100	8	2
101 to 150	11	2
151 to 200	14	2
201 to 300	14	2
301 to 400	14	2
401 to 500	14	2

TABLE 21.07-10: ACCESSIBLE PARKING SPACES		
Total Parking Spaces Provided	Total Accessible Spaces Required	Number of Accessible Spaces that shall be Van-Accessible
501 to 1000	3 percent of total	1 for every 6 accessible spaces
1001 and over	20 plus 2 for each 100 over 1000	1 for every 6 accessible spaces

2. Administrative Adjustments

The traffic engineer may approve administrative adjustments to the required number of accessible parking spaces, provided the applicant provides the federal minimum required number of accessible parking spaces and demonstrates the adjustment is necessary to compensate for a practical difficulty of the site. The department shall keep record of the approved adjustment with written findings supporting the adjustment on file and available for public inspection.

3. Passenger Loading Zones Attendant Parking

If passenger loading zones are provided, then at least one passenger loading zone shall be an accessible passenger loading zone. The requirements of table 21.07-11 do not apply to attendant parking spaces.

4. Multifamily and Mixed-Use Residential

Two percent, but not less than one space, of the parking spaces provided for a multifamily or mixed-use residential development with type A and type B dwelling units as defined in AMC title 23 shall be accessible.

5. Medical Facilities

At least 10 percent of patient and visitor parking spaces provided to serve hospital outpatient facilities shall be accessible. At least 20 percent of patient and visitor parking spaces provided to serve rehabilitation facilities and outpatient physical therapy facilities shall be accessible.

6. Location

Accessible parking spaces shall be located on the shortest accessible route of travel from adjacent parking to an accessible primary entrance. The accessible route of travel shall not pass behind parking spaces. In parking facilities that do not serve a particular building, accessible parking spaces shall be located on the shortest accessible route of travel to an accessible pedestrian entrance of the parking facility. In buildings with multiple accessible primary entrances with adjacent parking, accessible parking spaces shall be dispersed and located closest to the accessible entrances.

7. Location—Exceptions

In multilevel parking structures, van accessible parking spaces are permitted to be located on one level. Accessible parking spaces shall be permitted to be located in different parking facilities if it is demonstrated to the traffic engineer that substantially equivalent or greater accessibility is provided in terms of distance from an accessible entrance(s), parking fee, and user convenience.

8. Use of Required Accessible Parking

Required accessible parking facilities shall be used only for the parking of passenger automobiles of the residents, occupants, customers, visitors, or employees of the use. Accessible parking spaces and aisles shall be kept clear of obstructions, parking of equipment, and storage of goods or vehicles.

9. **Dimensions**

Car accessible spaces shall be at least eight feet wide with an access aisle at least five feet wide abutting the space. Van accessible spaces shall be at least eight feet wide with an abutting access aisle at least eight feet in width. When two or more accessible parking spaces are required per Table 21.07-10, spaces shall share a common access aisle between them.
10. **Maximum Grade**

Accessible parking spaces and access aisles shall have surface slopes not exceeding two percent in all directions.
11. **Accessible Routes**
 - a. **Location**

At least one accessible route to the building or facility entrance shall be provided from accessible parking and passenger loading zones.
 - b. **Surface Textures**

Ground surfaces along accessible routes shall be stable, firm, and slip-resistant.
 - c. **Changes in Levels**

Changes in level up to one-fourth inch may be vertical and without edge treatment. Changes in level between one-fourth inch and one-half inch shall be beveled with a slope no greater than one to two. Changes in level greater than one-half inch shall be accomplished by means of a ramp.
 - d. **Gratings**

If gratings are located in walking surfaces on an accessible route, then they shall have spaces no greater than one-half inch wide in one direction. If gratings have elongated openings, then they shall be placed so that the long dimension is perpendicular to the dominant direction of travel.
 - e. **Ramps**

ADA ramps cannot protrude into the ADA access aisle. Ramp details shall be included on the plans.
12. **Signs and Striping**

Each accessible parking space shall be designated as reserved by pavement markings and a sign showing the symbol of accessibility. Van-accessible spaces shall have an additional sign reading "Van-Accessible" mounted below the symbol of accessibility.

 - a. Signs shall be located so that they do not obstruct the ramps or other pedestrian access.
 - b. An accessible parking sign detail shall be included in the plan submittal per M.A.S.S.
 - c. All accessible spaces and aisles shall be striped with blue paint to color specifications prescribed by the *Manual of Uniform Traffic Control Devices*, including the total length of the curb encompassing the accessible parking space and accessible aisle.
11. **Implementation of ADA**

Regulations may be promulgated under section 21.03.210, *Title 21–Text Amendments*, to implement the requirements of Americans with Disabilities Act of 1991 as it may be amended or interpreted by federal regulation.

12. Standards for Parking as Principal Use

Where a parking structure or lot is a permitted principal or conditional use and the parcel is not accessory to another use on the same lot, accessible parking spaces in accordance with this section shall be provided.

K. Bicycle Parking Spaces

1. Applicability

This subsection is effective beginning January 1, 2024, and applies to the uses in Table 21.07-11: *Bicycle Parking Spaces Required*. Uses listed in subsection 21.07.090K.3. are exempt.

2. Bicycle Parking Required

Table 21.07-11 establishes the minimum number of bicycle parking spaces required per principal use, and the percentage of these spaces required to be developed as long-term (employee, resident) bicycle parking, versus short-term (visitor) spaces. The requirements are intended to follow the recommendations in the *Anchorage Non-Motorized Plan*. The required minimum number of spaces is calculated as follows:

- a. A minimum of two bicycle parking spaces shall be provided for each use in Table 21.07-11.

TABLE 21.07-11: BICYCLE PARKING SPACES REQUIRED

Use/Category Type	Minimum Number of Bicycle Spaces ¹ ("sf" = square feet; "gfa" = gross floor area)	Minimum Percentage for Long-Term Spaces (for required bicycle parking in excess of 2 spaces) ²
Multifamily and mixed-use dwellings	1 space per 5 dwellings	75 percent ³
Group living uses, Roominghouses, Homeless and transient shelters	1 space per 5 beds	75 percent
Government administration & civic facility, Offices, Hospitals/Healthcare Facilities	1 space per 5,000 sf gfa	75 percent
Cultural Facilities, Entertainment & Recreation Facilities	1 space per 10,000 sf gfa	10 percent
Schools, Colleges	4 spaces per classroom	25 percent
Restaurants, Bars	1 space per 3,000 sf gfa	10 percent
Retail Sales, Personal Service, Repair & Rental	1 space per 5,000 sf gfa	10 percent
Visitor Accommodations	1 space per 23,000 sf gfa	75 percent
Industrial uses	1 space per 25,000 sf gfa	75 percent
Uses not included above, except as provided in subsection K.3. below	Minimum of 2 spaces	Not required

¹A minimum of 2 spaces are required for each use. After the first 40 bicycle parking spaces, no additional bicycle parking is required for any individual non-residential use.

²The first 2 required spaces are not used in calculating the percentage of required long-term spaces. The number of required long-term bicycle parking spaces is calculated as a percentage of the overall number of required spaces beyond the first two required spaces.

³For multifamily and mixed-use dwellings, the requirement for a minimum percentage of required bike spaces to be long-term spaces is applicable only to buildings with five or more dwellings. All townhouse-style buildings are exempt from the long-term space requirement.

3. Exemptions

The bicycle parking requirements in subsection 2. shall not apply to:

- a. Household living dwelling units with their own individual garages.

- b. Airstrips.
- c. Utility Substations, Telecommunications facilities, and WECS.
- d. Natural resource extraction.
- e. Impound yards and storage yards.
- f. Any other non-residential use which has no regular employees or people on premises.

4. Administrative Adjustments

The director and traffic engineer may approve administrative relief or adjustments to the bicycle parking requirement or bicycle facility development standards, provided the applicant demonstrates the adjustment is necessary to compensate for a practical difficulty of the site. The department shall keep record of the approved adjustment with written findings supporting the adjustment on file and available for public inspection.

5. Co-Located Bicycle Parking

Bicycle parking spaces may be co-located for different uses on the same property if bicycle facility development standards are met. The total required bicycle parking spaces shall be the sum of the required parking for the individual uses.

6. Bicycle Parking Facility Development Standards

These requirements shall apply to all required bicycle parking spaces, except as specifically provided otherwise.

- a. Required bicycle parking or a sign leading thereto shall be located in an area visible from a primary entrance area.
- b. A required bicycle parking space shall be either a bike rack or bike locker. Each shall be a securely anchored, tamper-resistant structure. Bike racks shall allow the bike frame and one wheel to be locked to the rack with a standard U-type lock when both wheels are left on the bicycle. Bike racks shall support the bicycle frame in a stable position without damage to the bicycle. Horizontal bike racks (i.e., racks not mounted to walls) shall support the bicycle at two or more points.
 - i. Bicycle rack tubing shall be a minimum of ¼-inch diameter and maximum of 3-inch diameter.
 - ii. The topmost attachable portion of bicycle racks shall be 25 inches to 40 inches in height.
- c. A required bicycle parking space shall be a minimum of six feet long and two feet wide, with the following exceptions:
 - i. Vertical bicycle parking spaces (securing the bicycle perpendicular to the ground) shall be a minimum of three feet six inches deep measured from the wall and six feet six inches tall. Vertical parking spaces placed side-by-side shall be a minimum of one foot six inches wide, with a vertical stagger of one foot between side-by-side spaces, as shown in the first set of figures below.
 - ii. Triangle bike locker layouts are exempt from the two-foot minimum width however shall have a minimum length of six feet six inches and access doors at least two feet six inches wide.
 - iii. Stacked bike parking spaces (stacking bicycles one tier on top of another) may meet the alternative stacked dimensions in the bottom figures provided there is a mechanically assisted lifting mechanism for mounting the bicycle on the upper tier.

Dimensions for Horizontal/Side-by-Side and Vertical/Wall-Mounted Bicycle Spaces:

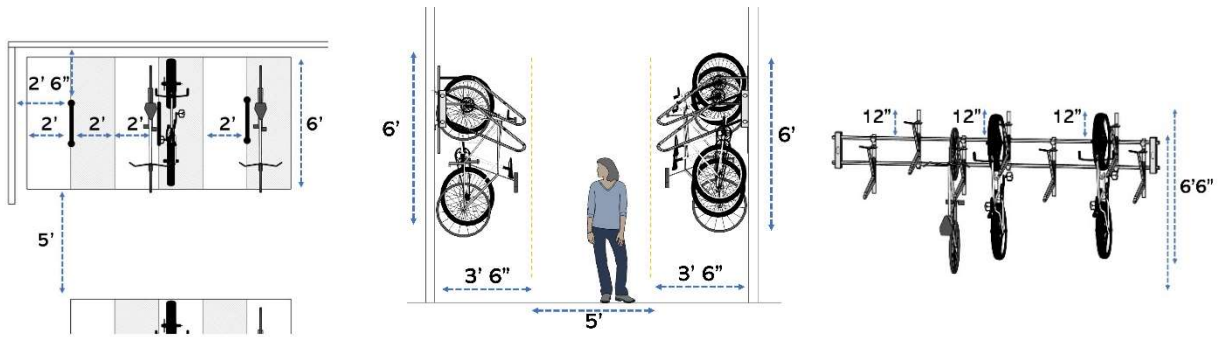

Dimensions for Stacked Bicycle Spaces:

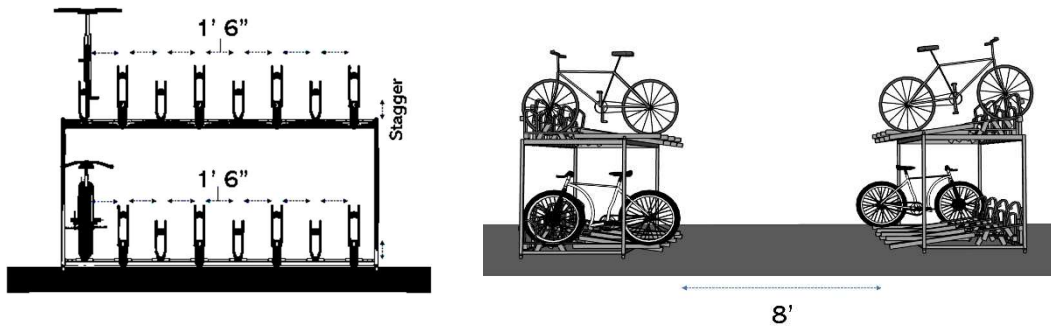

- iv. Other deviations are permitted, per director approval, provided the applicant demonstrates the spaces meet the intent of the standard.
- d. Bicycle parking spaces shall be designed so that the bicycle may be added or removed without having to move another bicycle.
 - i. There shall be a minimum of five feet of clear space inclusive of a walkway, behind the parking space to allow room for bicycle maneuvering.
 - ii. There shall be a minimum of two-foot six-inch clearance from all sides of the bicycle rack to walls, fences, curbs, and vehicle parking and circulation areas, or other obstructions, except for racks provided in iii.
 - iii. Horizontal bike parking spaces (securing the bicycle horizontal to the ground) with racks attached to walls shall have a minimum one-foot clearance from the rack to the wall, as shown in the second figure below. Vertical and stacked spaces have no required wall clearance.

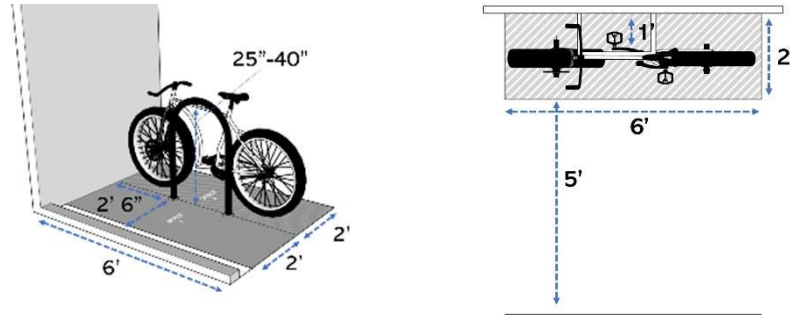

- e. Areas devoted to bicycle parking facilities shall be illuminated, hard-surfaced, and designed and maintained to be clear of obstructions, mud, and snow.
- f. Bicycle parking shall not obstruct pedestrian walkways, building access, or other use areas.

7. Development Standards for Long-Term Spaces

Long-term bicycle parking spaces are intended to accommodate bicyclists who typically need to store a bicycle overnight or for an entire work shift or school day. In addition to the standards in subsection 6., required long-term spaces shall comply with the following additional standards:

- a. Long-term bicycle parking shall be located in illuminated restricted access, lockable rooms or indoor or outdoor enclosures providing protection from theft, vandalism, and weather. Bicycle lockers, covered bicycle cages, or a secure room inside a building are common examples. A bicycle parking area located in a secure part of the building, such as an employee area not accessible to the public, is also acceptable.
- b. Long-term bicycle parking spaces shall be located where bicyclists are not required to carry bicycles on stairs to access the parking.
- c. Required long-term spaces shall not be located within dwelling units, or on a balcony, deck, or patio area accessory to an individual dwelling unit.
- d. A minimum of 30 percent of long-term spaces shall be level with the floor such that bicyclists do not have to lift a bicycle overhead to park it.

L. Vehicle Queuing Spaces

The vehicle queuing space requirements of this section shall apply unless otherwise expressly approved by the traffic engineer in accordance with L.7. below:

1. General

Uses of land and structures requiring vehicles and customers waiting in vehicles for service at drive-through facilities, pump stations, auto service bays, or similar uses, shall provide sufficient queuing spaces within the site to avoid impeding traffic movement in the public right-of-way. Such uses shall demonstrate to the traffic engineer that sufficient in-line waiting spaces are provided on-site as part of the parking plan to ensure the queue does not extend into the adjacent street, and that queuing minimizes interference with parking facility circulation aisles.

2. Minimum Number of Queuing Spaces Leading to Service Window

Any use listed in table 21.07-12, *Vehicle Queuing Spaces*, shall provide the number of on-site queuing spaces indicated in the table for each service window. The required number of queuing spaces does not include the vehicle space to be provided at the pick-up window, teller machine, or other station where the service occurs.

TABLE 21.07-12: VEHICLE QUEUING SPACES

Activity Type	Minimum Queuing Spaces
Financial institution teller lane	4 before teller or window
Automated teller machine drive-through	3 before teller machine
Restaurant drive-through	With no ordering board/window, 4 before pick-up window; with ordering board/window, 4 before ordering board plus 4 between ordering board or window and pick-up window
Car wash bay, automatic	5 before entrance to car wash bay
Car wash bay or stall, self-service	2 before entrance to car wash bay or stall
Food and beverage kiosk	3 before pick-up window
Fueling station pump island	2 at each end of pump island lane
Security gate entrance for self storage or vehicle storage facility	The queuing lane before the security gate shall measure a minimum of 50 feet in length and 24 feet in width. The width of the self-storage security gate is excluded.
Parking garage or structure	See subsection 21.07.090M., <i>Structured Parking</i>
School	See subsection 21.07.090I., <i>Passenger Loading Zones</i>
Other use with lane of vehicle queuing spaces	Determined by traffic engineer.

3. Queuing Lanes Leaving the Use

Queuing lanes shall be integrated with the on-site circulation and shall merge with the circulation aisle instead of exiting directly into a public right-of-way, except where the traffic engineer approves otherwise. The queuing lane may merge directly into a driveway, subject to approval by the traffic engineer. A minimum of 30 feet of queuing lane shall be required between the service window, bay, or station, and the point of vehicle egress to the adjacent parking facility circulation aisle, street, or right-of-way, however the traffic engineer may require more. The length and design of the queuing lane leaving a car wash bay or stall shall ensure the water and ice from vehicles do not adversely affect adjacent streets, storm drainage systems, or the safe circulation of vehicles and pedestrians.

4. Queuing Dimensions

Queuing lanes shall have a minimum width of 10 feet along straight portions and 12 feet along curved segments. Queuing spaces shall have a minimum length of 20 feet.

5. Traffic Circulation Conflicts

Queuing spaces shall not interfere with on- or off-site traffic movements or movements into or out of off-street parking and loading areas.

6. Delineation

Queuing spaces shall be delineated from other queuing lanes, driveways, internal circulation and parking aisles, loading areas, and refuse collection areas by striping, curbing, landscaping, alternative paving materials, or raised medians. Walk-in customer crosswalks across queuing lanes shall be avoided to the extent reasonably feasible and permitted upon approval by the traffic engineer. If approved, such crosswalks shall provide mitigation such as warning signage aimed at both the pedestrian and vehicle.

7. Exceptions

The traffic engineer may approve a reduction in the number of required queuing spaces or other departure from the queuing space requirements if documentation prepared by a traffic engineering professional demonstrates to the satisfaction of the traffic engineer that the change is appropriate and consistent with the intent of the requirements. The applicant

shall enter into an agreement with the municipality which is recorded, runs with the use of the land, and ensures continuation of the alternative strategy and the future implementation of contingency measures if ordered by the traffic engineer.

M. Structured Parking

1. Purpose

Parking structures and structured parking within buildings shall comply with the provisions of this subsection, in order to be compatible with the architectural character and quality of adjacent buildings; avoid adverse impacts to abutting sidewalks or residential properties; use color, massing, and other architectural features to reduce apparent bulk; and screen potential visual impacts from garage lighting or parked vehicles. It is also the intent of this section to ensure safe and convenient vehicle access and parking, and to avoid impeding traffic on adjacent streets and pedestrian facilities.

2. Applicability

This subsection M. applies to all parking structures and structured parking within buildings, with the following exceptions:

- a. The requirements do not apply to garages for individual dwellings.
- b. Where at-grade parking is provided under or partially under a building, the ground floor level of any side of the building that abuts surface parking on the same site (i.e., the surface parking extends or continues under the building) is exempt from this subsection.

3. Ground Floor Use

In the B-3, R-3A, R-4, and R-4A districts along streets that have been specifically designated in the comprehensive plan as a main street, transit street, mixed-use street, or with a similar street typology, ground-floor structured parking shall be enclosed along that street frontage by a first-story habitable space that:

- a. Has a minimum depth of 25 feet;
- b. Extends the full length of the building elevation facing the designated street, excluding pedestrian and vehicle entrances and exits, stairwells, elevators, and centralized payment booths;
- c. Is designed and used for residential, community, office, retail, or other commercial use; and
- d. Includes ground floor windows providing visual access and/or primary entrances that comprise at least 25 percent of the ground level wall area.

4. Façade Treatment

The street-facing façade of a parking structure shall have a repeating pattern that includes no less than three instances of either (1) color change, (2) texture change, (3) material module change, or (4) expression of an architectural or structural bay through a change in plane no less than 12 inches in width, such as an offset, reveal, or projecting rib. At least one of these elements shall repeat at an interval of not more than 30 feet. The director may approve an alternative design to this standard if, through the alternative equivalent compliance process, the applicant can demonstrate an alternative building design that significantly articulates a wall plane.

5. Screening

Ground floor structured parking within a building shall be screened by a wall or façade or other architectural treatment consistent with the rest of the building in terms of style, detail, and materials. The perimeter of each parking structure floor above the ground floor shall

have an opaque screen or other screening mechanism to shield vehicle headlights from public view. The screen shall be at least three and one half feet high measured from the finished floor elevation. An architectural treatment, such as a finished fascia, shall be provided to shield any unfinished structural elements such as electrical elements, exposed metal beams, and mechanical appurtenances. Lights visible from the exterior of the structure shall be covered or screened with a diffusing lens and oriented to minimize the visual impact on adjacent streets and properties.

6. Landscaping

The perimeter of a parking structure shall be planted with L1 visual enhancement landscaping in any commercial or DT district, except at points of vehicular and pedestrian entrance and exit, where the structure abuts an alley right-of-way, where the structure directly abuts another building, or where there is a ground floor use that meets the standards of subsection M.3. above.

7. Ingress and Egress

- a. Non-automated parking structures designed to provide more than 500 parking spaces shall have at least two vehicle entrance driveways and two vehicle exit driveways.
- b. Vehicle entrance driveways shall provide a minimum of one queuing space in addition to the vehicle space at the ticket dispenser or access reader, unless a traffic analysis indicates more queuing is needed. Such queuing space(s) shall meet the standards of subsection 21.07.090L., *Queuing Spaces*.
- c. Vehicle exit driveways shall provide a minimum of 30 feet of on-site vehicle queuing that does not interfere with any parking spaces, rights-of-way, access easements, pedestrian facilities, or private streets.
- d. Minimum width of 20 feet for 2-way ingress/egress entries for parking structures. Formal waiver required from municipal traffic engineer for a reduction/exception to this standard.

8. Maximum Gradients

The maximum gradient of parking aisles shall be six percent. The grade of non-parking ramps shall be no greater than 12 percent, and shall comply with the requirements of Americans with Disabilities Act of 1991 as it may be amended or interpreted by federal regulation. Where special circumstances warrant, the traffic engineer may approve steeper grades according to accepted engineering practices, subject to special conditions of approval such as an ice-free (snow melting) ramp surface.

9. Layout and Internal Circulation

The configuration of parking and dimensions within a non-automated parking structure shall be subject to the requirements of table 21.07-9: *Parking Angle, Stall, and Aisle Dimensions*, except that a modified layout and internal circulation pattern may be approved by the traffic engineer when it can be shown that a structure meets the design guidelines of the latest Urban Land Institute, Parking Institute, or Institute of Transportation Engineers manuals.

10. Automated Parking Structures

- a. Automated parking structures shall require a traffic analysis and be subject to review and approval by the traffic engineer.
- b. Automated parking structures are exempt from the parking space and aisle dimensions and vertical clearance requirements of this section.
- c. Automated parking structures shall be located wholly within an enclosed building and shall not be visible from outside the building or facility.

- d. Automated parking structures shall be operated as attendant parking.

(AO 2012-124(S), 2-26-13; AO 2013-117, 12-3-13; AO 2014-58, 5-20-14; AO 2015-82, 7-28-15; AO 2015-100, 10-13-15; AO 2015-131, 1-12-16; AO 2016-3(S), 2-23-16; AO 2017-55, 4-11-17; AO 2017-176, 1-9-18; AO 2019-132, 12-3-19; AO 2020-38, 4-28-20; AO 2021-89(S), 2-15-22; AO 2022-80(S), 11-22-22; AO 2023-77, 7-25-23; AO 2023-50, 7-11-23; AO 2024-24, 4-23-24)

21.07.100 EXTERIOR LIGHTING

Nonresidential Uses and Districts

All parking facilities in nonresidential zoning districts and parking facilities which serve nonresidential uses shall have lighting which meets the level of illumination, uniformity ratios, and minimum lumen intensities specified in the illumination guidelines set by the Illuminating Engineering Society of North America. The lighting system shall be designed to prevent glare to motorists on public streets and light trespass onto adjoining property.

(AO 2012-124(S), 2-26-13; 2015-131, 1-12-16)

21.07.110 RESIDENTIAL DESIGN STANDARDS

A. Purpose

The standards of this section 21.07.110 are intended to promote high-quality residential development and construction; protect property values; encourage visual variety and architectural compatibility; and promote an integrated character for the municipality's neighborhoods. Specifically, the standards:

1. Promote new residential developments that are distinctive, have character, and relate and connect to established neighborhoods.
2. Avoid monotony in structure design and site layout by providing variety and visual interest in the exterior design of residential buildings.
3. Enhance the residential streetscape, walkability, and the pedestrian environment by diminishing the prominence of garages and parking lots.
4. Improve the compatibility of residential development with the residential character of surrounding neighborhoods and protect property values of both the subject property and surrounding development.
5. Provide flexible standards that allow for creativity and innovation, site-specific responses, and investment in new housing opportunities.

B. Alternatives and Flexibility

1. Alternative Equivalent Compliance

The alternative equivalent compliance procedure set forth in subsection 21.07.010D. may be used to propose alternative means of complying with the intent of this section. Structures over eight units may apply directly to the urban design commission for alternative compliance with plans at least 15 percent complete, that include exterior elevations and dimensions, floor plans, landscaping, and parking plans.

2. Minor Modifications

Minor modifications may be applied, pursuant to section 21.03.120, *Minor Modifications*.

3. Design Innovation Credit

The decision-making body may approve design innovations not covered by the menu choices, to be used as credit for design features from the menus of this section. The

applicant shall demonstrate a specific feature that realizes the intent of the subsection and that:

- a. Achieves an equal or better design solution for the development than would result from application of the basic menu choices; and
- b. Does not adversely affect adjacent properties or streets.

4. Topography

Where a standard or menu choice applies to a building elevation facing a street, and the average grade plane of the street-facing side of the building is at least eight feet lower than the average grade plane of the abutting sidewalk (or edge of street pavement where there is no sidewalk), the standard or menu choice shall only apply to the portion of the elevation that is above the average grade plane of the abutting sidewalk (or street edge).

C. Standards for Multifamily and Townhouse Residential

1. Purpose

The purpose of these standards is to improve the appearance, livability, compatibility, and functionality of multifamily and townhouse development, recognizing the importance of these elements to supporting the economic success of neighborhoods, more compact and efficient land use and infill housing, and adequate protection of the surrounding area. These standards are intended to encourage multifamily neighborhood environments which are safe and inviting for walking and cycling, outdoor activity, and transit access, and so reducing vehicle and traffic impacts on denser areas. Specific objectives include:

- a. Promote architectural elements that reduce the perceived mass of larger buildings, avoid blank walls along visible facades, and provide visual variety and human scale elements at/near the ground floor.
- b. Promote sensitive design and site planning for denser compact housing, with respect to surrounding properties, adjacent outdoor activities, and neighborhood scale and context.
- c. Promote building placement and orientation that interfaces with the neighborhood street and engages the pedestrian, to contribute to public safety, attractive street frontages, pedestrian access, and a sense of neighborhood and community.
- d. Promote project design and site planning that considers Alaska's northern climate in terms of weather protection, daylighting, outdoor activity, and access to sunlight.
- e. Provide pedestrian access to building entries that is clearly defined, safe, and inviting for people of all abilities.
- f. Provide relief, including landscaped breaks, from expanses of paved parking, rows of garage doors and townhouse driveways, and unsightly project elements.
- g. Ensure flexibility of building and site design standards to facilitate multifamily development and redevelopment in urban and suburban areas responding to site specific characteristics, street typologies, neighborhood context, and the comprehensive plan.

2. Applicability

These standards apply to:

- a. Any multifamily or townhouse development with five or more units; and
 - i. Existing buildings being converted to multifamily are exempt from this section.

- b. The residential portion of a mixed-use structure;

This section does not apply in Girdwood or the DT districts.

3. Pedestrian Oriented Street Frontage Standard

Provisions for site planning and building orientation in relationship to street frontages and pedestrian access are provided subsection 21.07.060F., *Pedestrian Frontage Standard*.

4. Building Spacing

- a. When the front wall or rear wall of a row of dwelling units faces the front wall or rear wall of another row of dwelling units on the development site, the average distance between shall be a minimum of 24 feet, plus one foot of distance for each foot of building height above 24 feet, up to a maximum requirement of 30 feet.
- b. When the end wall of a row of dwelling units faces the front wall or rear wall of another row of dwelling units on the development site, the average distance between shall be a minimum of 20 feet.
- c. End walls facing end walls are not subject to the building spacing requirement of this section.
- d. Building projections allowed under subsection 21.06.030C.2. are permitted to project into the required space between buildings.
- e. For the purposes of this subsection 21.07.110C.4., front walls and rear walls are defined as those walls that are generally perpendicular to party walls between dwelling units. End walls are generally parallel to party walls separating dwelling units, and are located at the end of a row of units. Front and rear walls in a building are typically the primary location of openings for light and air for the dwelling units, while end walls are not.

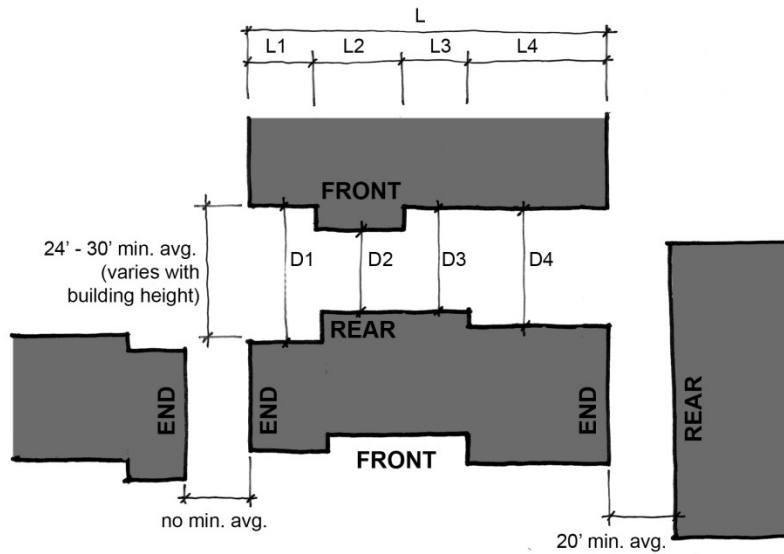

for articulated facades: $[(L1 \times D1) + (L2 \times D2) + (L3 \times D3) + (L4 \times D4) \dots] / L \geq \text{min. avg.}$

5. Building Articulation Menu

Any building elevation facing a street or having a primary front entrance shall provide at least four features from the menu below, except that the end walls of rows of dwelling units may provide as few as three features. This section shall apply to no more than two building

elevations, with priority to at least one elevation facing a street. Each building elevation may use different menu choices.

a. Wall Articulation

Articulate the building using wall plane projections or recesses, with changes in plane of at least 18 inches in depth. Space at intervals that relate to the location and size of individual dwelling units or living spaces, or to the number of units across the façade, or that are no more than 30 feet on average (spacing may vary). Provide such articulation for the majority of the building wall height.

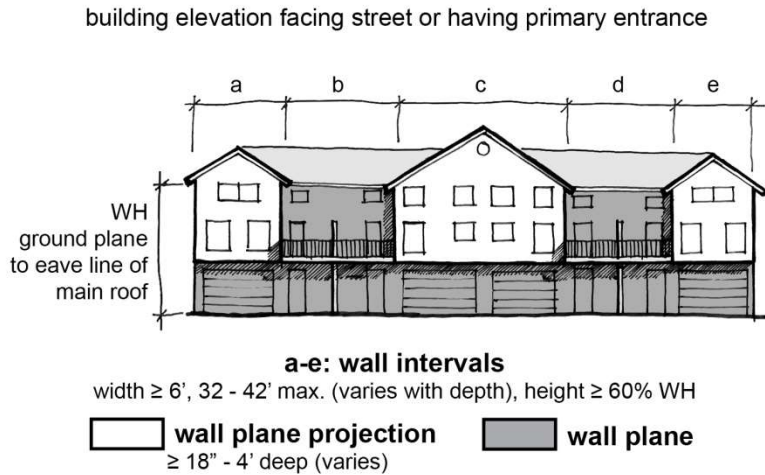

b. Overall Building Modulation

Provide wall plane projections or recesses having a depth equal to at least 10 percent of the length of the building elevation or 4 feet (whichever is less), and whose combined wall area comprises at least 25 percent of the building elevation wall area. This menu choice counts as two features if the change in plane is double the minimum width.

c. Upper Story Cantilever or Step-Back

Cantilever or step-back an upper story for the majority of the building elevation length, with a change of wall plane of at least 18 inches.

d. Variation of Exterior Finishes

Use two or more primary wall siding materials, or a change of color only if the color change is to a different primary or secondary color family and is delineated with trim or a change in wall plane, not including concrete or block foundation.

e. Ornamental Features and Detail Elements

Use two or more façade detail features at intervals, such as medallions, shutters, columns, pilasters, wall modulations that don't meet subsections 5.a. or 5.b. above, balconies that don't meet 5.f. below, trim that is three and one half inch wide or wider, or other similar features approved by the director.

f. Balconies

Incorporate balconies with a depth of at least four feet and repeated at intervals across the building length (spaced as stated in menu choice 5.a. above).

- g. **Bay Windows**
 Incorporate bay windows extending at least 18 inches from the abutting wall plane, and repeated at intervals across the building length (spaced as stated in menu choice 5.a. above).
- h. **Additional Window Area**
 Provide windows and/or primary entrance doors comprising at least 20 percent of the wall area of the building elevation. Windows in a garage door do not count towards the minimum area in this section.
- i. **Entry Articulation**
 Enhance the articulation of the primary front entrance (or at least 50 percent entries when not every entry faces the street) with a sheltering roof structure, projecting vestibule, or wall projections/recesses, having a depth of at least four feet for the width of the entry space.
- j. **Building Elevations Free of Garage Doors**
 Provide the building elevation without garage bay doors.
- k. **Additional Foundation Landscaping**
 Provide a foundation planting bed along at least two-thirds of the foundation wall with a planting bed at least eight feet in depth, and planted with at least two trees and six shrubs per 20 linear feet of building length.
- l. **Roofline Modulation**
 Provide variations in roof form, orientation, or height using features such as a terracing parapet, multiple peaks, jogged ridge lines, projecting roof forms and dormers, provided at intervals above the main eave line (spaced as stated in menu choice 5.a. above). The vertical dimension of the roofline variation shall be at least the greater of two feet or 10 percent of the wall height.

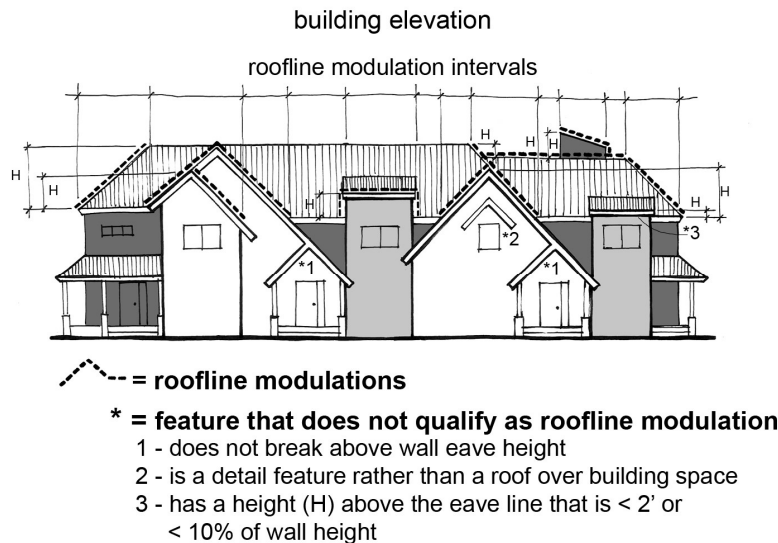

- m. **Variation in Building Form or Scale**
 Provide a minimum of two kinds of variation in architectural form or scale, such as between individual dwellings in a building, or from one building to the next in the development. Variations may include reversed building elevations, a different pattern or arrangement of building modulation or articulation features, a different dwelling unit layout or design that is evident on the exterior, or a change in scale

such as varying the number of stories, the number of units from one building to the next, or the width of abutting units.

n. **Director Approval**

Other methods, as approved by the director, that reduce the scale of multifamily buildings or add visual interest.

6. **Northern Climate Weather Protection and Sunlight Menu**

Building and site design shall respond to Alaska's northern climate, including the effects of snow, ice, low temperatures, wind exposure, and low and seasonal sunlight conditions, which impacts the pedestrian environment and livability of denser compact housing areas, by providing at least four features from the following menu on buildings comprised of eight or more units. Menu choices 6.f., *Year-Round Access to Sunlight*; 6.g., *Sunlight Access for Neighbors*; 6.i., *Sun Trap*; 6.j., *Atrium*; and 6.l., *Sunlit and Wind Protected Courtyards*, shall each count as two features. The director has the ability to reduce the number of required features in circumstances where site conditions or scale of buildings do not support the features provided in the menu options.

a. **Weather Protected Entrance**

Provide outdoor shelter as a permanent architectural feature, that covers at least 24 square feet of outdoor entryway space for each primary front entrance.

b. **Covered Transition Spaces**

Provide outdoor shelter as a permanent architectural feature that covers at least 40 square feet of outdoor space for each dwelling unit for front porches, rear patios, balconies, or similar indoor-outdoor transition spaces. Spaces may be provided for each dwelling unit or aggregated for a common space. Spaces that achieve this and menu choice 6.a. above shall receive credit for both.

c. **Sheltered Passenger Loading Zone, Bicycle Parking, or Transit Stop**

Provide pedestrian shelter over a passenger loading zone, accessible parking aisle or route, bicycle parking, or a transit shelter.

d. **Ice-Free Walkway**

Provide an ice-free (snow melting) walkway for a required walkway connection to a primary entrance.

e. **Orientation for Sunlight Access**

Provide windows and/or primary entrances for at least 20 percent of the wall area with a solar orientation and demonstrate each is likely to receive at least six hours of sunlight access on March/September 21. Natural features existing at the time of development, such as trees, shall not be considered as blocking sunlight access, but newly installed evergreen trees shall be planted so as to minimize blocking of sunlight access.

f. **Year-Round Access to Sunlight**

Ensure that one or more windows of every dwelling in the development will receive sunlight access for at least one hour on December 21. Natural features existing at the time of development, such as trees, shall not be considered as blocking sunlight access, but newly installed evergreen trees shall be planted so as to minimize blocking of sunlight access.

g. **Sunlight Access for Neighbors**

Preserve sunlight access at least six hours daily on March/September 21 to any adjacent lot zoned PR, any sidewalk across the street, and neighboring residentially zoned property, through building placement, massing, and height.

h. Daylighting

Provide for apartment daylighting and building spacing as follows: Locate at least one window in the main living area of each dwelling such that an imaginary daylight plane extending from the window and formed by an angle of 60 degrees that is unobstructed for a horizontal distance of 60 feet. The plane angle shall be measured horizontally from the center of the bottom of the window. As an alternative, two angles with a sum of 60 degrees may be used.

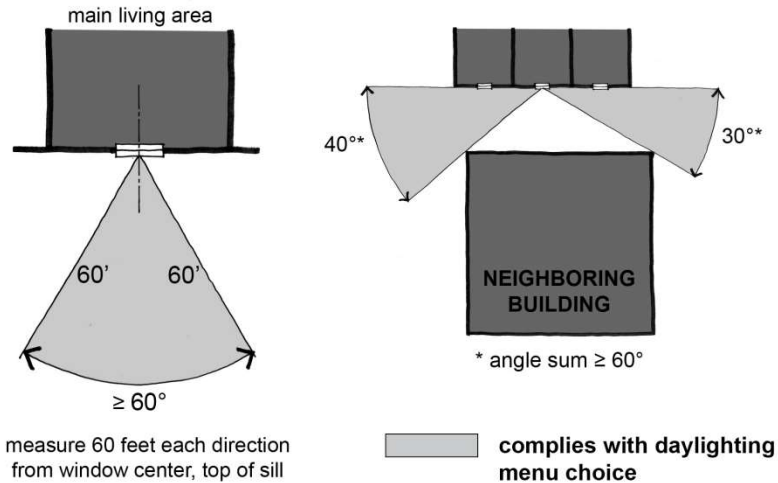

i. Sun Trap

Incorporate a sun trap or “pocket” meeting the requirements of subsection 21.07.060G.12, *Sun Pocket*, as part of a common private open space.

j. Atrium

Provide an atrium interior sunlit common private open space or primary entrance area, meeting the requirements of subsection 21.07.060G.11., *Atrium, Galleria, or Winter Garden*.

k. Stepped or Terraced Building Forms

Provide a stepped or terraced building form above the second story that adheres to a daylight plane with a step-back angle no steeper than one foot of rise per one foot of run, to reduce the potential shadowing and wind turbulence effects of a tall building.

l. Sunlit and Wind Protected Courtyards

Provide a housing courtyard as described in subsection 21.07.060G.7.

m. Wind Study

If subsection 21.07.120C.1. applies, then credit for this feature shall be given.

n. Director Approval

Other methods not listed in this menu may be approved by the director following a finding that the proposed alternative methods effectively address northern climate considerations.

7. Landscaping

a. Semi-Private Transition Space

When site perimeter landscaping is not otherwise required for dwelling units that front onto a street, the area between an individual unit’s front entry porch or landing and the abutting street shall be planted as provided in 7.d. below. Front driveway

width and other motor vehicle parking facilities shall not encroach into this area. The director may modify or exempt this requirement in site specific instances (such as narrow lots and shared entry porches) that will not allow the area to extend to the street due to other requirements of code.

b. Front Driveway Separations

Where units are served by individual garages or driveways fronting onto the street or on the same building elevation as the primary front entry to the dwelling, a landscaping planting area with a width of no less than four feet shall be provided between each individual driveway. The planting area shall extend out from the building façade or front entry landing the full distance to the street, shared driveway, parking bay, or circulation aisle, but in no case extend out less than eight feet from the building garage facade. Driveways may be combined for a maximum of two dwellings, however no driveway or driveway combination shall exceed 32 feet in width without a landscaped break. A parking courtyard may provide an alternative design that departs from this provision in accordance with subsection 21.07.060G.23.

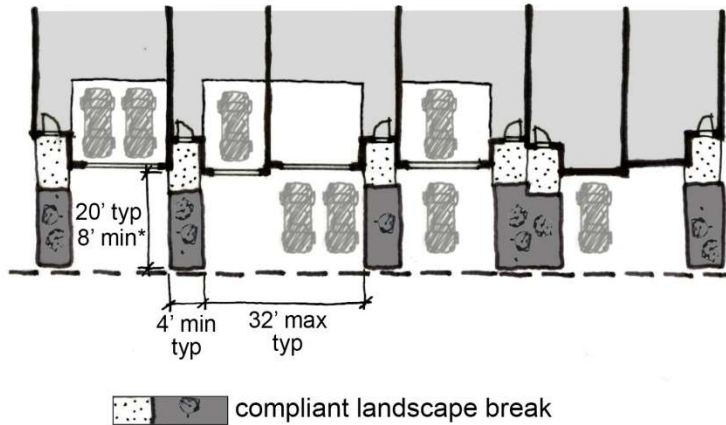

c. Common Parking Facilities and Driveways

A foundation planting bed of at least five feet in width shall separate parts of residential building elevations not subject to subsections 7.a. or 7.b. above from common parking and access facilities, including parking bays, circulation aisles, and access driveways shared in common among multiple units.

d. Landscaping Bed and Planting Material Standards

i. Landscaping areas required by subsections 7.a. and 7.b. above shall be planted as follows:

(A) Where the building elevation is less than 20 feet from the street or driveway, the landscaping areas shall be planted with one tree and five shrubs for every two dwelling units. No landscaping area shall be devoid of plant material.

(B) Where the building elevation is 20 feet or more from the street or driveway, the landscaping areas shall be planted with one tree and five shrubs in front of each dwelling.

ii. The foundation planting bed area in subsection 7.c. above shall be planted with at least ten shrubs per 20 linear feet of applicable building length. Trees may be used in lieu of shrubs with one tree replacing five shrubs.

- iii. The director may modify or exempt the standards where it can be shown that plantings would interfere with solar panels, foundation insulation, or other elements that promote other objectives in title 21.

8. Mechanical and Electrical Equipment Screening

Mechanical and electrical equipment serving a single building shall be screened from view as required by subsection 21.07.080G.4.

D. Standards for Some Single-Family and Two-Family Residential Structures, and Multifamily and Townhouse Developments with Less Than Five Units.

1. Applicability

The standards of this subsection D. apply to the developments listed below that are constructed after January 1, 2014. This section does not apply to dwellings constructed prior to January 1, 2014, accessory dwelling unit uses, or in Girdwood or the DT districts.

- a. Any single-family use except for single-family residential uses on lots of 20,000 square feet or greater.
- b. Any two-family use that is on a lot less than 20,000 square feet.
- c. Any multifamily use with single-family or two-family style construction with less than five units.
- d. Multifamily and townhouse developments with less than five units.

2. Mix of Housing Models

Any subdivision or development of five or more principal structures shall have a mix of housing models, as determined during the building permit process, according to table 21.07-13: *Mix of Housing Models*. This applies to abutting or adjacent lots.

TABLE 21.07-13: MIX OF HOUSING MODELS	
Number of principal structures	Number of different models required
5-10	2
11-20	4
21-30	5
31 or more	6

Each housing model shall be noticeably different through at least three of the following variations. For the purposes of this provision, “noticeably different” means a change that is easily apparent when looking at building plans and elevation drawings, without resorting to using measurements and scales/rulers in order to determine a difference in design.

- a. Window placement and entrance location.
- b. Façade detail elements, siding material, or siding colors.
- c. Placement of the building footprint on the lot. A four foot setback differential to the closest front corner of the adjacent façade shall be acceptable.
- d. Garage placement.
- e. Roof design/feature. This includes the main ridgeline being oriented differently, two or more additional roof planes, addition of at least one dormer, or a different roof style.

- f. Exterior elevations.
- g. Building massing.

The development (of five or more units) shall be arranged to avoid placing identical housing types, including mirror image floor plans, on lots that share side lot lines.

3. Pedestrian-Oriented Street Frontage Standards.

Provisions for site planning and building orientation in relationship to street frontages and pedestrian access are provided in subsection 21.07.060F., *Pedestrian Frontage Standard*.

E. Site Design

1. Subdivisions

Subdivisions of land shall comply with the standards of chapter 21.08, *Subdivisions*.

2. Multiple Structures on One Lot

a. Intent

This section regulates the development of multiple residential structures on a single lot. The section is intended to allow flexibility from the subdivision regulations while still achieving neighborhoods that are healthy, safe, and convenient, and meet the goals of the comprehensive plan. The approval processes and standards are intended to result in a development with a cohesive neighborhood identity, an attractive and functional streetscape, a hierarchy of streets and driveways, convenient and safe pedestrian circulation, sufficient parking near each dwelling unit, usable and well-located open space, a positive image of higher density residential development, and well designed and visually pleasing structures and neighborhoods.

b. Applicability

This section applies to the development of five or more principal residential structures on a single lot. It does not apply to the development of an accessory dwelling unit or a caretaker's unit, or to developments in the R-4A district, or to developments of two to four principal residential structures.

c. Review Process

- i. Multiple residential structures on a single lot are permitted in the R-2M, R-3, R-3A, R-4, R-4A, B-1B, B-3, and RO districts.
- ii. Applicable developments with between five and 30 dwelling units shall be approved by administrative site plan review pursuant to subsection 21.03.180C. Applicable developments with 31 or more dwelling units shall be approved by major site plan review pursuant to subsection 21.03.180D.

d. Approval Criteria

All approvals under this section shall use the approval criteria below, in addition to the general site plan review approval criteria. The decision-making body may place conditions on the development as it may deem necessary to meet the approval criteria.

- i. The proposal shall clearly distinguish between streets and driveways. Streets shall allow vehicles to travel into and within the development, and shall be the means for assigning an address to dwelling units. Driveways shall access garages and parking areas. Some small developments may not need a street network.
- ii. Dwelling units shall be oriented towards streets (either within the development or along the boundary of the development) or towards a

courtyard or similar common open space. Buildings with frontage on both a street and a driveway shall be oriented towards the street. If the development is so small that no internal street network is necessary, then buildings and dwelling units shall be oriented towards the local public streets on the boundaries of the development, or towards common open space.

- iii. The area between the front of a unit facing a street and the street shall include landscaping or lawn, so that the streetscape features green space rather than just paved parking areas. Adequate snow storage area shall be provided. On-street parking shall be accommodated (if provided).
- iv. Developers should make every effort to design and arrange dwelling units in such a manner as to provide “eyes on the street,” take advantage of solar access, and to the extent feasible, provide privacy for neighboring units’ yards.
- v. In addition to sidewalks required by section 21.07.060, pedestrian pathways shall be provided to large open space areas and in the middle of long blocks. Pedestrian circulation should be convenient both within the development and to appropriate neighboring areas outside the development.
- vi. The development is designed to take advantage of any significant natural features on site, and to provide usable open space and recreation areas.

e. ***Development Agreement***

The developer shall enter into a development agreement with the department, using the provisions established in subsection 21.03.100E., *Improvements Associated with Land Use Permits*.

f. ***Minimum Standards***

All development with multiple residential structures on a single lot shall meet the following minimum standards, in addition to the applicable standards of this title.

i. ***Open Space***

For developments with 31 or more dwelling units, at least half of the private open space required by section 21.07.030 shall be provided as common private open space, meeting the standards of section 21.07.030, and designed and placed to serve all residences. The decision-making body may adjust the amount of open space required to be common by up to 10 percent, based on written findings regarding site specific conditions.

ii. ***Building Spacing***

If subsection 21.07.110C.4. does not apply, then the following shall apply: within a development, no portion of any single-, two-, or three-story building shall be closer than 10 feet from any other single-, two-, or three-story building. All portions of any building taller than three stories shall be separated by no less than 20 feet from any other building.

iii. ***Guest Parking***

Locate guest parking spaces as to minimize maneuvering in private streets and circulation aisle and not exclusive to or physically associated with any individual dwelling.

F. Affordable Housing

1. Purpose

This subsection provides the minimum acceptable standards for affordable housing units that are intended to be counted towards a bonus incentive or any other requirement of this title, to ensure that affordable housing will provide a benefit to future residents and the community overall.

2. Standards

Affordable housing units shall meet the following standards in order to be credited towards a requirement, menu choice, or as a special feature bonus incentive of this title.

- a. The affordable housing units shall meet the definition of affordable housing in chapter 21.15.
- b. To determine if the housing units meet the definition for affordable housing, the housing cost burden to households shall be calculated based on the household and unit size assumptions in table 21.07-14: *Household and Unit Size Assumptions* below, unless the housing development is subject to different assumptions imposed by other governmental regulations.

TABLE 21.07-14: HOUSEHOLD AND UNIT SIZE ASSUMPTIONS	
Unit Size	Household Size
Studio or efficiency	1 person
1 bedroom	2 persons
2 bedroom	3 persons
3 bedroom	4 persons
Each additional bedroom	Add one person

- c. An owner that receives a floor area bonus for affordable housing shall enter into a written agreement with the municipality, as provided in subsection 21.06.030E. The agreement shall ensure the housing units will remain available and affordable as long as the development uses the FAR bonus, or for a period of 20 years from the date the final certificate of occupancy is granted, whichever is less.
- d. The property owner shall submit an annual report to the department, using a form provided in the title 21 user’s guide, that documents compliance with the affordable housing requirements.
- e. At least 50 percent of the habitable floor area of affordable housing units shall be located in a story above grade plane, as defined in chapter 21.15, except that the finished surface of the floor above the affordable housing unit shall be a minimum of four feet above grade.
- f. The affordable housing units shall be intermingled with all other dwelling units in the development.
- g. The exterior appearance of the affordable housing units shall be indistinguishable from the other dwelling units in the development, except where the director determines that the exterior is compatible in appearance and consistent in quality with the other dwelling units.

G. Conditional Use for a Residential Planned Unit Development

1. Intent and Approval

A residential planned unit development (PUD) is intended to allow flexibility for residential development in the zoning ordinance and to achieve the creation of a more desirable environment than would be possible through a strict application of the zoning ordinance.

A residential PUD shall be processed as a conditional use in accordance with section 21.03.080. The planning and zoning commission shall evaluate the proposed planned unit development in accordance with the conditional use approval criteria at section 21.03.080D., and the following additional criteria:

- a. Creative use of the land, imaginative architectural design, a consolidation of usable open space and recreation areas, and the preservation of natural features.
- b. The mixing of compatible land uses, residential densities, and housing types within the neighborhood.
- c. The efficiency of the configuration of utilities, vehicular circulation, and parking facilities.
- d. Enhancing the surrounding environment.
- e. Maintaining population densities and lot coverage that are consistent with available public services and the comprehensive plan.

2. Minimum Standards

All planned unit developments shall meet the following minimum standards. In addition, the planning and zoning commission may require compliance with such other design standards relating to the construction, design, and placement of buildings, landscaping, streets, roadways, walkways, drainageways, and other site design features as it may deem necessary. A PUD shall comply with any special limitations of the zoning district.

a. *Minimum Site Area*

The minimum site area for a PUD shall be 2.0 acres for PUDs located entirely in the R-2M, R-3, R-4 and R-4A zoning districts. If any portion of a proposed PUD is located within the R-1, R-1A, R-2A, R-2D, R-5, R-7, GR-1, GR-2, GR-2A, GR-3, GR-4, or GR-5 zoning districts, the minimum site area shall be 5.0 acres. If any portion of a proposed PUD is located within the R-6, R-8, or R-9 zoning districts, the minimum site area shall be 10 acres.

b. *Open Space*

A minimum of 30 percent of the site shall be reserved as open space which shall meet the following standards:

- i. At least one-half of such open space shall be contiguous;
- ii. The open space shall not include public or private streets or rights of way; parking facilities, driveways, other motor vehicle circulation areas, loading areas, or refuse collection areas; slopes over 15 percent; 50 percent of designated snow storage areas; drainage easements, ditches, swales, or other areas intended to collect and channel water;
- iii. In class A districts, no portion of the required open space shall be less than 2,000 square feet in area or less than 30 feet in its smallest dimension, except for individual yards, balconies, or decks pursuant to b.iv. and b.v. below;
- iv. In class B districts, no portion of the required open space shall be less than half of the minimum lot size of the underlying district in area, or less than 100 feet in its smallest dimension, except for individual yards, balconies, or decks pursuant to b.v. and b.vi. below;

v. A minimum of 12 percent and a maximum of 50 percent of required open space shall consist of yards which shall be reserved for the residents of individual dwelling units; and

vi. In multistory buildings, balconies or decks may be used in lieu of individual yards provided that the total area of all balconies or decks is not less than the total yard area otherwise required.

c. **Design**

i. Any nonresidential use permitted in a PUD shall be compatible with the residential nature of the development. Parking areas which are intended to serve nonresidential uses shall be separated from those designed to serve residential areas. Unless nonresidential and residential uses are combined within a single structure, nonresidential uses shall be separated from dwelling units by L2 buffer landscaping.

ii. Pedestrian walkways shall connect residential and nonresidential uses within a PUD.

iii. L2 buffer landscaping shall be planted along each boundary of the PUD adjacent to a nonresidential district or a right-of-way designated for collector or greater capacity on the *Official Streets And Highways Plan*.

iv. Common open space with L3 screening landscaping shall be provided along any lot line abutting a residential neighborhood where any abutting lot is greater than 150 percent of the average lot size along that lot line of the PUD.

v. Any two adjacent buildings within a PUD shall be separated from each other by a distance equal to one-half the height of the taller building.

d. **Access and Connectivity**

PUDs shall comply with section 21.07.060, *Transportation and Connectivity*.

e. **Utility Installation**

All new utilities shall be installed underground.

f. **Homeowners' Agreements**

Any PUD which will involve the formation of a horizontal property regime under the terms of AS 34.07.010 et seq. or any mandatory homeowners' or similar association shall submit for review by the commission the articles of incorporation and bylaws of any such association prior to the sale of any property subject to the association. The commission may require any provisions necessary to ensure that the provisions and intent of this title are met.

3. **Development Options**

The following provisions allow the developer of the PUD to propose changes from the provisions of the underlying zoning district with regard to density, allowed uses, and dimensional standards. The extent of the changes to the standards shall be determined by the planning and zoning commission in accordance with the approval criteria of subsection G.1. above.

a. **Density**

The number of dwelling units per acre allowable on the gross area of a PUD shall be determined by the planning and zoning commission. However, in no event shall the number of dwelling units per acre exceed the maximums established by the following schedule:

TABLE 21.07-15 Maximum Dwelling Units per Acre in a PUD	
Zoning District	Dwelling Units per Acre (gross area)
R-1 and R-5	8
R-1A	6
R-2A	12
R-2D	15
R-2M	22
R-3	55
R-4	110
R-4A	110
R-6	2
R-7	4.5
R-8	0.5
R-9	1.0
GR districts	As determined by the planning and zoning commission

b. Uses

The applicant may propose any residential use, and in class A zoning districts, may propose any commercial use that is allowed in the R-4 district in table 21.05-1. A PUD may not include the storage or use of mobile homes or quonset huts. Any nonresidential use must be specifically authorized as to its exact location, type, and size. In no event shall the total gross floor area of all nonresidential uses exceed 10 percent of the total gross floor area of the PUD.

c. Dimensional Standards

- i. Height limitations in the R-1, R-1A, R-2A, R-2D, R-2F, R-2M, R-6, R-7, R-8, R-9, GR-1, GR-2, GR-2A, GR-3, GR-4, or GR-5 zoning districts may be exceeded by an additional five feet. Height limitations in the R-3, R-4 and R-4A districts may be exceeded by an additional 10 feet.
- ii. The applicant may propose changes to minimum lot area, maximum lot coverage, and minimum setbacks for the PUD.

4. Planned Unit Developments in the Turnagain Arm District

PUDs in the TA district shall conform, with regard to uses and residential density, to the land use plans of the *Turnagain Arm Area Plan* and the standards of this section.

(AO 2012-124(S), 2-26-13; AO 2013-117, 12-3-13; AO 2014-132, 11-5-14; AO 2015-36, 5-14-15; AO 2015-100, 10-13-15; AO 2016-34(S), 4-12-16; AO 2016-136, 11-15-16; AO 2017-160, 12-19-17; AO 2018-59, 7-31-2018; AO 2019-132, 12-3-19; AO 2020-38, 4-28-20; AO 2021-89(S), 2-15-22; 2022-80(S), 11-21-22; AO 2023-30, 3-22-23; AO 2023-42, 8-22-23; AO 2023-50, 7-11-23; AO 2023-103(S), 12-18-23; AO 2024-24, 4-23-24)

21.07.115 NONRESIDENTIAL DEVELOPMENT

A. Conditional Use for a Business-Industrial Park Planned Unit Development

1. Intent and Approval

A business-industrial park planned unit development (BIP-PUD) is intended to provide comprehensively planned commercial-industrial developments that are compatible with surrounding areas. BIP-PUD developments should have integrated, campus-style site plans designed to accommodate a variety of public/institutional, commercial, and industrial uses. High standards for

architecture, landscaping, and site planning are encouraged. A BIP-PUD shall be processed as a conditional use in accordance with section 21.03.080. The planning and zoning commission shall evaluate the proposed planned unit development in accordance with the conditional use approval criteria at section 21.03.080D.

2. Zoning District

A BIP-PUD is allowed only in the B-3 and I-1 districts. Business-industrial parks existing on January 1, 2014 in other zoning districts shall be considered conforming in those districts.

3. Allowed Uses

- a. For a BIP-PUD in the B-3 district, in addition to the uses allowed in the B-3 district, a developer may propose to include the following industrial uses in a BIP-PUD: general industrial service; governmental service; manufacturing, general; warehouse or wholesale establishment, general.
- b. For a BIP-PUD in the I-1 district, in addition to the uses allowed in the I-1 district, a developer may propose to include the following uses in a BIP-PUD: child care center, health services, and government administrative and civic facilities, if the location of the latter is consistent with subsection 21.05.040C.4.b.ii.
- c. For initial uses proposed in the BIP-PUD that require a conditional use approval, the conditional use application(s) may be combined with the BIP-PUD conditional use and treated as one application and approval process.

4. Development Agreement

The developer shall enter into a development agreement with the private development division, using the provisions established in subsection 21.03.100E., *Improvements Associated with Land Use Permits*.

5. Minimum Standards

All BIP-PUDs shall meet the following minimum standards, in addition to the applicable standards of this title. The planning and zoning commission may apply additional standards as it may deem necessary to meet the approval criteria.

- a. The minimum site area for a BIP-PUD is seven acres.
- b. In keeping with a campus-style site plan, the number of access points to the BIP-PUD shall be limited to only what is necessary, as determined by the traffic engineer.
- c. Pedestrian walkways shall be provided to streets abutting the BIP-PUD. All transit stops abutting a BIP-PUD shall be connected to the internal street/sidewalk system by a pedestrian walkway. Where abutting streets have no transit stops, the BIP-PUD shall have a pedestrian walkway connection to the abutting street at least every 500 feet, unless the abutting street is a restricted access street without pedestrian facilities.
- d. L2 buffer landscaping shall be provided along the exterior lot lines of the BIP-PUD.
- e. A BIP-PUD shall have a defined internal street system, which shall have pedestrian facilities and landscaping in accordance with the provisions of this title. Streets shall allow vehicles to travel into and within the development. Driveways shall access parking areas.

- f. Except for stand-alone restaurants located along an outside edge of a BIP-PUD, all buildings shall have a common architectural character utilizing similar materials. The standards of section 21.07.130 shall not apply.
- g. Maximum individual building footprint shall be 30,000 square feet.
- h. Individual tenancies for health services; and office, business or professional, shall not exceed 5,000 square feet.
- i. Individual tenancies for government administration and civic facilities and religious assembly shall not exceed 15,000 square feet.
- j. Individual tenancies for instructional services and uses in the retail sales use category shall not exceed 20,000 square feet.
- k. Loading areas and refuse collection areas shall be internal to the site and not located between any building and any BIP-PUD exterior lot line.
- l. The maximum floor area devoted to retail sales uses shall not exceed 35 percent of the total gross building area of the entire development.
- m. Outdoor storage and display is prohibited.

B. Conditional Use for a Planned Unit Development in the DT Districts

1. Intent and Approval

A planned unit development (PUD) is intended to allow flexibility in the zoning ordinance and to achieve the creation of a more desirable environment than would be possible through a strict application of the otherwise-applicable requirements of the zoning ordinance. The planning and zoning commission shall evaluate the proposed planned unit development in accordance with section 21.03.080 and the following approval criteria:

- a. The creative use of the land, imaginative architectural design, a consolidation of usable open space and recreation areas and the preservation of natural features.
- b. The mixing of compatible land uses, residential densities, and housing types within the neighborhood.
- c. The efficiency of the configuration of utilities, vehicular circulation, and parking facilities.
- d. Enhancing the surrounding environment.
- e. Maintaining population densities and lot coverage that are consistent with available public services and the comprehensive plan.

2. General provisions

All residential, business and industrial planned unit developments shall meet the following minimum standards. In addition, the planning and zoning commission may require compliance with such other design standards relating to the construction, design and placement of buildings, landscaping, streets, roadways, pathways, drainageways and other site design features as it may deem necessary.

- a. *Minimum site area.* The minimum site area for a planned unit development shall be 2.0 acres for PUDs located entirely in the DT districts.
- b. *Grading plan.* Building design and site development which involve excessive grading for the placement of structures, parking areas, driveways and roadways shall be depicted on a site plan and shall be described in the written documents.

- c. *Traffic access.* Major internal streets which are intended to serve a planned unit development shall be functionally connected to existing or proposed streets to provide adequate ingress and egress.
- d. *Utility installation.* All new utilities shall be installed underground.
- e. *Conformance with comprehensive plan.* A planned unit development shall be in accordance with the comprehensive plan.
- f. *Landscaping.* All areas not devoted to buildings, structures, drives walks, off-street parking facilities or other authorized installations shall be planted with visual enhancement landscaping.
- g. *Fire safety requirements.* All developments shall meet fire safety requirements established by the municipal fire department.

3. Standards

A PUD in this section may include only those uses which are permitted principal uses and structures in its applicable DT district, provided that no use involving outdoor storage of inventory, hotel uses or wholesale uses shall be permitted where it would not otherwise be permitted in that district. In addition to meeting standards set forth in the general provisions, PUDs shall meet the following minimum standards:

- a. Buffer landscaping shall be planted along each boundary of a business planned unit development that abuts a residential district.
- b. Safe and convenient pedestrian circulation shall be provided.
- c. Principal vehicular access points shall permit smooth traffic flow with controlled turning movements and to minimize hazards to vehicular or pedestrian traffic. Access points shall be located in relation to major thoroughfares so that traffic congestion will not be created by the proposed development.
- d. The maximum number of residential dwelling units per acre allowable within the PUD shall be determined by the following schedule. If the PUD is designed to include residential uses, the area to be devoted to such uses shall be identified on the PUD site plan, and the allowable density shall be calculated based only upon the areas indicated for residential use:

Zoning District	Dwelling Units per Acre (gross site area)
B-2A	180
B-2B	120
B-2C	150

(AO 2015-36, 5-14-15; AO 2020-38, 4-28-20; AO 2023-50, 7-11-23; AO 2024-24, 4-23-24)

21.07.120. LARGE ESTABLISHMENTS

A. Large Commercial Establishments

Large commercial establishments often have high visibility from major public streets and a great volume of use by many residents and visitors. As a consequence, their design determines much of the character, function, and image of this community and its streetscapes and commercial areas.

The purpose of this section is to encourage major commercial developments to contribute to and respect the municipality as a unique place and to physically integrate with the community in a positive and architectural and site design sensitive manner. The standards of this section augment existing basic standards for development found elsewhere in this chapter with more specific interpretations that apply to large commercial establishments. These standards promote: a basic level of architectural variety and interest; a compatible appearance and scale; pedestrian and parking lot access; orientation of buildings and entrances in relation to surrounding streets; provisions for adaptive reuse of prominent vacant buildings; and mitigation of negative impacts of large scale commercial developments.

1. Applicability

The standards of this section 21.07.120 shall apply to any use in the Retail Sales; Animal Sales, Service, and Care; Food and Beverage Services; Entertainment and Recreation use categories; the Vehicle Parts and Supplies, Vehicle-Large Sales and Rental, Vehicle-Small Sales and Rental; and Marijuana Retail Sales Establishment use types, or any combination thereof, occupying more than 20,000 gross square feet of floor area, provided the following limitations:

- a. The standards of this section shall apply only to buildings, and the non-residential portions of mixed-use buildings, which are intended principally for the uses listed above.
- b. This section shall not apply to distinct floors and/or sections of buildings designed specifically for residential, office, or other uses not listed in subsection 21.07.120A.1. above.
- c. [RESERVED—POTENTIAL AMENDMENTS TO SELF-STORAGE FACILITIES IN 21.05 TO ADDRESS MULTI-STORY FACILITIES]

2. Relationship to Other Standards

The provisions of this section shall apply in addition to all other generally applicable standards found elsewhere in this chapter and title. Where there is a conflict with generally applicable standards in this chapter, the standards of this section shall apply. Where there is a conflict with district-specific standards in chapter 21.04 of this title, the district-specific standards shall apply.

3. Alternative Equivalent Compliance

The alternative equivalent compliance procedure in subsection 21.07.010D. may be used to propose alternative means of complying with the intent of this section. Applicants for alternative equivalent compliance shall demonstrate design strategies that address each of the mandatory standards set forth below in subsection A.5.

4. Major Site Plan Review

All applicable large commercial establishments shall be approved by major site plan review in accordance with section 21.03.180. The applicable commission shall ensure that the site plan provides architectural variety, compatible scale, access amenities, mitigation of negative impacts, and convenience and safety of patrons.

5. Mandatory Standards

a. Vehicular Access

Primary vehicular access shall be from a street designated collector or greater on the *Official Streets and Highways Plan*. Secondary vehicular access may be from a street designated less than a collector, provided the applicant demonstrates that any traffic and visual impacts on adjacent residential and commercial areas are sufficiently minimized.

b. Parking

Aesthetic features, landscaping, and the design of parking lots shall reduce the appearance of large expanses of parking from neighboring streets, and enhance the view of the establishment from its principal point(s) of access.

c. *Weather Protection for Pedestrians*

- i. Buildings and roofs shall be designed so that drainage from the roof shall not fall on sidewalks, walkways, or building entrances.
- ii. All primary entrances shall have a roof, canopy, arcade, overhang, or similar effective weather protection that meets the standards of subsection 21.07.060G.9., *Pedestrian Shelter*.
- iii. Building elevations that face public streets or customer parking lots and that have a walkway along the façade shall provide weather protection meeting the standards of subsection 21.07.060G.9., *Pedestrian Shelter such as a Canopy, Awning, or Marquee*, or subsection 21.07.060G.10., *Arcade (or Building Recess)*, along at least 60 percent of such building elevation. This standard is intended to apply to up to two elevations, but the applicable commission may increase or reduce the requirement.

d. *Adjacent Residential Development*

L3 screening landscaping shall be provided along property lines that are adjacent to a residential district. The landscaping shall allow for any pedestrian connections provided by this section.

e. *Community Space*

The establishment shall provide at least one public space, such as a plaza, patio, courtyard, or atrium, either indoors, outdoors, or a combination of indoors/outdoors, at or near the principal customer building entrance. Each public space shall be no less than 5 percent of the gross building area, up to a maximum of 2,000 square feet, and no dimension shall be less than 30 feet. Outdoor community space shall meet the standards for plaza or courtyard in subsection 21.07.060G.6. Indoor community space shall meet the standards for atrium, galleria, or winter garden in subsection 21.07.060G.11. Common spaces are encouraged to provide views of the Chugach mountains or other major landmark(s). Community space fulfills the private open space requirement of section 21.07.030. If any standards of this subsection conflict with subsection 21.07.030, this subsection shall control.

f. *Wall Modulation*

Each building elevation that faces a street or a customer parking lot shall be modulated. The wall and foundation line shall be offset at intervals so that there is at least one offset every 140 feet of wall length that varies the depth of the building wall by a minimum of 12 feet. Offsets shall comprise at least 20 percent of the length of the elevation, for at least 60 percent of the building height.

g. *Ground Level Expression*

Each building elevation that faces a public street shall provide, along at least 60 percent of the building length, three of the following features:

- i. Windows with kickplates or projecting sills;
- ii. Architectural bays and mullions dividing windows;
- iii. Pedestrian scale ornamental lighting;
- iv. Tilework, masonry or stone veneer, glass block, or other similar accent materials;

- v. Belt courses or masonry strips of distinct color or texture;
 - vi. Columns with plinths; or
 - vii. Other façade detail features integrated into the façade design.
- h. *Materials and Colors***
The buildings shall have exterior building materials and colors which are aesthetically pleasing and compatible with the overall site plan. Construction material shall provide color, texture, and scale.
- i. *Roofs***
Provide a modulated roof on each building elevation facing a street or residentially zoned lot, using features such as a terracing parapet, multiple peaks, jogged ridge lines and dormers, with a maximum of 140 feet of uninterrupted roofline between roof modulation elements. Each modulation element shall provide a minimum of three feet of vertical change in the roofline. Modulation elements shall equal at least 20 percent of the roofline on each applicable building elevation.
- j. *Entryways***
Primary entrances shall incorporate changes in architectural mass, surface, or finish to provide a clearly defined primary entrance that is easily visible from streets and sidewalks. At least two of the following features shall be provided:
- i. Recessed or projected entrance;
 - ii. Peaked, arched, or other entrance roof form;
 - iii. Transom or clerestory windows, along with double entry doors and sidelight windows;
 - iv. Façade detail features such as tilework, moldings, or lighting, integrated into the building design; or
 - v. Integrated planters or wing walls that incorporate landscaped and/or seating areas.
- k. *Prohibited Materials***
Exterior building materials shall not include the following as a general field material:
- i. Plywood;
 - ii. Unstained or untreated wood, except for cedar or redwood; and
 - iii. T-111 siding.
- l. *Mechanical and Electrical Equipment Screening***
Large commercial establishments shall comply with the mechanical and electrical equipment screening provisions of subsection 21.07.080G.4.
- m. *Outdoor Sales, Display, and Storage***
- i. *Intent Statement*
To screen storage and display areas of large commercial establishments from adjacent properties, public streets, and customer entrances, and to mitigate visual and noise impacts, and to provide different standards for vehicle sales display.
 - ii. *Permanent Outdoor Display, Sales, and Storage of Merchandise, Except Vehicles for Sale*

- (A) Any outdoor storage, display, or sales location shall be permanently defined on a site plan.
 - (B) The maximum size of permanent outdoor storage, display, and sales areas shall be 10 percent of the footprint of the principal building, or 15,000 square feet, whichever is less.
 - (C) Permanent outdoor storage, display, and sales areas shall be contiguous to the building and shall not be within 100 feet of residential property.
 - (D) All outdoor storage, display, and sales areas shall have permanent walls and/or screening fences, no more than 15 feet high, made of materials and colors designed to be complementary to those used as predominant materials and colors on the building. Merchandise shall not be stacked above the height of the screening wall or fence.
 - (E) Outdoor storage, display, and sales areas shall be counted when calculating required parking.
- iii. *Outdoor Sales and Display of Vehicles for Sale*
- (A) The vehicle display area shall be permanently defined on a site plan.
 - (B) The vehicle display area shall not occupy required parking or landscaping areas.
 - (C) The vehicle display area shall comply with subsection 5.b. above. The vehicle display area shall not adversely impact vehicular or pedestrian circulation within the parking lot or access to the parking lot.
 - (D) No building shall be erected in the vehicle display area. Any area used for a temporary office shall be shown on the site plan.
- n. **Master Site Plan and Secondary Buildings**
- i. *Intent*
To integrate the location, orientation, and appearance of all structures and improvements within a large commercial establishment as a unified, coherent and accessible site development.
 - ii. *Master Site Plan*
Large commercial establishments on sites that include more than one building, or that include multiple pad lots or commercial tracts, shall, at the time of plat review or major site plan review, be required to establish a master site plan for the location, design and orientation of principal and secondary buildings on site.
 - iii. *Applicability of Large Commercial Establishment Regulations*
Building and site design standards for large commercial establishments in this section, unless stated to apply specifically to principal buildings, apply to both principal and secondary buildings on any commercial tract within a large commercial establishment site or site master plan area.
 - iv. *Secondary Building Orientation to Public Streets*
Peripheral secondary buildings located at the edge of the site next to a public street or street corner shall provide windows on the street-facing

elevation as follows: visual access windows and/or primary entrances for at least 35 percent of the length and 15 percent of the ground floor wall area. Qualifying windows shall be no more than four feet above finished grade.

6. Optional Standards Menu

In addition to the mandatory standards of subsection A.5. above, establishments shall choose two features from the options below.

a. *Location of Parking Lots*

No more than 50 percent of vehicle parking spaces provided shall be located in the front parking area (defined in chapter 21.15).

b. *Building Placement Close to the Street*

A minimum of 30 percent of the front building elevation of the principal building shall be within 20 feet of a property line abutting a street, and a customer entrance shall be located in the 30 percent.

c. *Pedestrian-Friendly Entrance*

At least one primary entrance of the principal building is located within 90 feet of the property line abutting the street from which the main access to the site is taken, and connected to the street by a direct walkway.

d. *Multiple Entrances*

The principal building(s) shall have customer entrances on at least two sides of the building that face an abutting street from which access to the site is taken, with at least one of the required entrances facing the street to which the building is closest. A corner entrance shall be counted as an entrance on either façade.

e. *Building Walkways*

Walkways a minimum of six feet unobstructed clear width, excluding vehicular overhang, shall be provided along the full length of every building elevation that has a customer entrance or abuts a customer parking lot.

f. *Street Facing Windows*

Provide visual access windows and/or primary entrances on each street-facing building elevation (up to a maximum of two elevations) comprising at least 15 percent of the ground-floor wall area. An elevation that is more than 150 feet away from the facing street right-of-way shall be exempt, unless it is the only applicable elevation. Qualifying windows shall be no more than four feet above finished grade.

g. *Screening Vegetation*

L3 screening landscaping shall be provided along lot lines that abut public streets, totaling at least 25 percent of the site perimeter.

h. *Foundation Landscaping*

Planting beds at least eight feet wide with one tree and six shrubs per 20 linear feet shall be provided along at least 50 percent of each building elevation that faces public streets and/or parking lots.

i. *Ice-free Walkway*

Provide an ice-free (snow melting) walkway along a minimum of 35 percent of the length of the building elevation that contains a primary entrance. The walkway shall be a minimum of six feet unobstructed clear width, excluding vehicular

overhang. This feature is not applicable for credit where the walkways and entrances are covered.

B. Large Non-Residential Establishments in or Surrounded by Large Lot Residential Districts

Certain non-residential uses that are allowed in large lot residential districts have the potential to create negative impacts on large lot residential neighborhoods when the nonresidential uses are significantly larger and more intensive than the typical development in these areas. This section provides consistent standards for such cases.

1. Applicability

The standards of this section shall apply to any child care center, neighborhood recreation center, religious assembly, educational facility (elementary, middle, or high school, or instructional services), commercial horticulture, animal boarding, veterinary clinic, cultural facility, or utility facility, or any combination thereof, where the sum of the gross floor area of all applicable buildings on the lot is more than 10,000 square feet, and the use is within a class B zoning district or the parcel under development abuts property in a class B zoning district for more than 50 percent of its boundary. Single-family residential dwelling units associated with such a use (e.g., a rectory) shall not be counted toward the gross floor area size threshold, but shall meet the standards below.

2. Relationship to Other Standards

The provisions of this section are in addition to other requirements of this title, and may be more stringent than other requirements of this title. Where there is a conflict with other applicable standards, the more stringent standard shall apply.

3. Setbacks

Structures that are over 35 feet in height shall be setback beyond the underlying side or rear setbacks of the district by one foot per foot of height over 35 feet.

4. Buffers

- a. L3 screening landscaping shall be provided along all lot lines that abut a residential zoning district or a street.
- b. The developer shall retain existing vegetation in buffer areas that are in the side and rear setbacks.
- c. The decision-making body may adjust the buffer requirements of subsections 4.a. and 4.b. above if the applicant demonstrates that the requirements are unreasonable for the specific situation.

5. Parking

- a. No parking lot, circulation aisle, driveway, loading area, or vehicular storage area shall be within 25 feet of any side or rear lot line.
- b. Vehicle storage and fleet vehicle parking are not allowed within setbacks equal to those of the abutting property.

6. Vegetated Open Space

A minimum of 35 percent of the lot area shall remain as planted open area, landscaped area, bio-retention area (and other similar vegetated area designed to retain/detain storm water runoff), or natural vegetation area, to exclude buildings, driveways, parking areas, sidewalks, etc., unless the decision-making body determines that retention of less than 35 percent provides a development character in keeping with the surrounding neighborhood.

7. Long Elevations

Building elevations longer than 100 feet that face residential lots or public streets shall provide façade modulations that meet either subsection 21.07.110C.5.a., or

21.07.110C.5.d., or provide an eight-foot wide foundation planting bed along the foundation of the entire elevation (breaks allowed for garage doors and pedestrian entrances), planted with at least one tree and six shrubs per 20 linear feet.

C. Tall Buildings

This section addresses the effects of tall buildings in Alaska's northern climate, including wind downdraft impacts on pedestrian comfort and safety, and shadowing impacts on sunlight access to neighboring properties.

1. Wind

Buildings that exceed 90 feet in building height (as measured in subsection 21.06.030D.), including additions or modifications to the exterior building envelope, shall be designed so that wind speeds on sidewalks, walkways, and other pedestrian spaces surrounding the building will remain within thresholds for outdoor comfort and safety, or at least not add to existing wind problems, as follows:

a. *Wind Speed Criteria*

Acceptable wind speed thresholds for outdoor comfort and safety shall be as supported by ASCE publications, and based on the types of pedestrian activity anticipated to occur around the proposed building.

b. *Method for Determining Wind Conditions*

A wind study by a wind engineering/building aerodynamics expert shall be used to forecast wind conditions and present wind control measures or design modifications as necessary to demonstrate that wind speeds will remain within the accepted thresholds.

c. *Incentives for Wind Mitigation*

Any development that incorporates a wind tunnel test and the wind speed criteria of this section into the design of a multistory building shall be eligible for a floor area bonus as provided in section 21.04.030H.2.b.

2. Sunlight Access

[RESERVED]

3. Exceptions

The director may allow wind speeds to exceed accepted thresholds for comfort, and/or shadowing beyond the accepted minimum threshold for sunlight access, if:

- a. The building avoids worsening pre-existing conditions;
- b. The impact will be insubstantial because of the limited location or time period in which the wind speed or sunlight shadowing threshold is exceeded; or
- c. It has been demonstrated that the proposed development conforms to the maximum extent feasible.

(AO 2012-124(S), 2-26-13; AO 2013-117, 12-3-13; AO 2017-121, 9-26-17; AO 2021-89(S), 2-15-22; AO 2023-42, 8-22-23)

21.07.130 SKYWALKS AND OTHER PROJECTIONS INTO PUBLIC AIRSPACE

[RESERVED: Updated land use regulations to address overpasses, skywalks, building marquees, and similar substantial projections into the public airspace from private property, will be prepared and adopted separately. These development standards will not apply to bridges that are part of the street and trail network. Instead, these development standards will be specific to updating the pre-existing title 21 regulations in order to provide for skywalks and other structures originating from private property and projecting over or across rights-of-way and other

public property. Standards for skywalks in the DT districts only are included in section 21.11.080.]

(AO 2012-124(S), 2-26-13; AO 2020-38, 4-28-20)

21.07.140 OPERATIONAL STANDARDS

A. Purpose

The purpose of these operational standards is to prevent land or buildings within the municipality from being used or occupied in any manner so as to create any dangerous, injurious, noxious, or otherwise objectionable condition that would create adverse impacts on the residents, employees, or visitors on the property itself or on nearby properties.

B. Applicability

The provisions of this section 21.07.140 shall apply to all land within the municipality. The director may authorize temporary exemptions from one or more of the standards in this section during construction.

C. Standard

No use may cause excessive noise, vibrations, smoke, dust or other particulate matter, toxic or noxious matter, humidity, heat, or glare at or beyond any lot line of the lot on which it is located. No equipment or process shall be used which creates visual or audible interference in any radio or television receivers off the premises, or causes a fluctuation in line voltage off the premises.

The term “excessive” is defined for the purpose of this subsection as to a degree exceeding that generated by uses permitted in the district in their customary manner of operation, or to a degree injurious to the public health, safety, welfare, or convenience.

(AO 2012-124(S), 2-26-13)